

IPS InLine® System

Instructions for Use



Optimize your working procedures and simultaneously increase the productivity and economic efficiency of your laboratory.

With the **IPS InLine** metal-ceramic system, you will have the flexibility required for today's everyday laboratory work - from simple layering to highly esthetic veneers.

The **IPS InLine** metal-ceramic system permits the fabrication of restorations shaded according to A–D, Chromascop, and Bleach shade guides.

After the application of the opaquer, you can choose the product and the corresponding processing procedure according to your personal preferences and the clinical situation:

- **IPS InLine One**: Straightforward one-layer metal-ceramic for quick and efficient layering
- **IPS InLine**: Conventional metal-ceramic for traditional, individualized layering
- **IPS InLine PoM**: Press-on-Metal ceramic for accurately fitting, fully anatomical press-on procedures

The IPS InLine System gives you the choice without increasing the number of components. Join in a new way to process metal-ceramic.

IPS InLine®

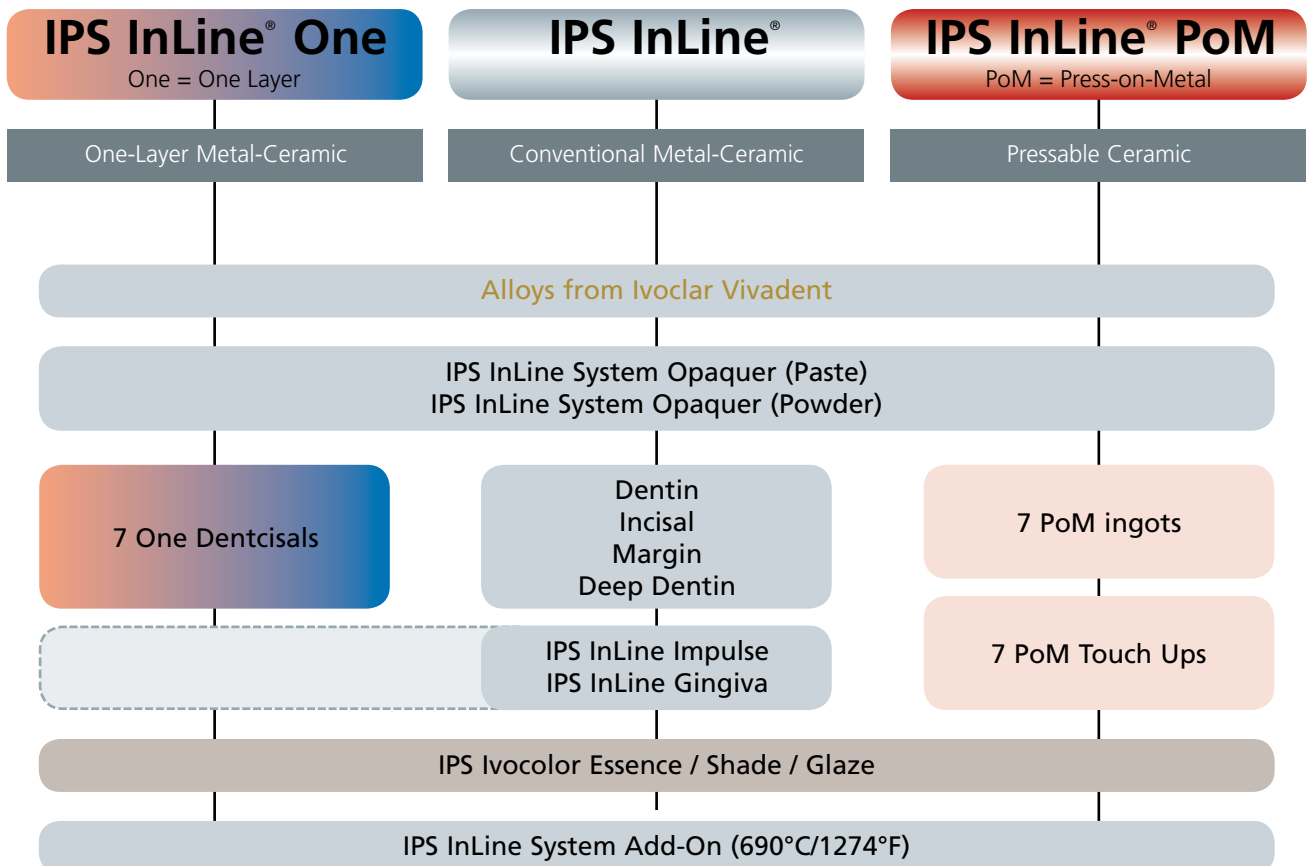

Table of Contents

5 Product Information

IPS InLine One – One-layer metal-ceramic
IPS InLine – Conventional metal-ceramic
IPS InLine PoM – Press-on-metal ceramic
Warnings
Properties
Coordinated Ivoclar Vivadent alloys
Preparation guidelines and minimum layer thicknesses

12 IPS InLine One – One-Layer Metal-Ceramic

Framework design criteria
Step-by-step procedure
Framework design
Alloy processing / oxide firing
Layering diagram IPS InLine One
Opaquer firing
Paste opaquer

- 1st opaquer firing (wash firing)
- 2nd opaquer firing

1st Denticisal firing
2nd Denticisal firing
Individual processing and preparing for Stain and Glaze firing

24 IPS InLine – Conventional Metal-Ceramic

Framework design criteria
Step-by-step procedure
Framework design
Alloy processing / oxide firing
Layering diagram IPS InLine
Opaquer firing
Paste opaquer

- 1st opaquer firing (wash firing)
- 2nd opaquer firing
- IPS InLine Opaquer F (optional)

1st and 2nd Margin firing (optional)
1st Dentin and Incisal firing
2nd Dentin and Incisal firing
Margin Add-On firing
Add-on material firing
Individual processing and preparing Stain and Glaze firing

Table of Contents

Practical Procedure – Metal-Supported Restorations

39 **IPS InLine PoM – Press-On-Metal Ceramic**

Framework design criteria
Step-by-step procedure
Framework design
Alloy processing / oxide firing
Layering diagram IPS InLine PoM
Paste opaquer

- 1st opaquer firing (wash firing)
- 2nd opaquer firing
- IPS InLine Opaquer F (optional)

Wax-up
Sprueing
Investing
Preheating
Ingot selection
Pressing with the 100 g, 200 g, 300 g IPS Investment Ring System
Divesting
Separating / finishing
Adjustments with IPS InLine PoM Touch Up
Individual processing and preparing Stain and Glaze firing

Practical Procedure – Metal-Supported Restorations

60 **IPS InLine – Veneers**

Fabricating the model (refractory die model)
Wash firing
Cervical firing
Dentin/Impulse firing
Incisal firing
Glaze firing
Divesting the veneers
Conditioning the veneers for adhesive cementation

IPS Ivocolor – Completion

62 **IPS Ivocolor – Completion**

Stain and Characterization firing

- IPS Ivocolor Shade
- IPS Ivocolor Essence

Glaze firing
Add-On after Glaze firing

General Information

67 **General Information**

Cementation
IPS InLine One firing parameters
IPS InLine firing parameters
IPS InLine PoM mixing ratio investment material / press parameters / firing parameters
IPS InLine Veneer firing parameters
Combination Tables

Symbols in the Instructions for Use



Important



Information



Tips & Tricks

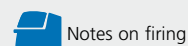

Notes on firing

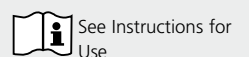

See Instructions for Use

Product Information

IPS InLine® One – One-Layer Metal-Ceramic IPS InLine® – Conventional Metal-Ceramic

Material

IPS InLine and IPS InLine One are veneering ceramic materials containing leucite. They are suitable for the fabrication of metal-ceramic restorations at firing temperatures higher than 900 °C (1652 °F). With both products, alloys in the CTE range of $13.8\text{--}15.0 \times 10^{-6}/\text{K}\text{-}1$ (25–500°C) can be veneered, irrespective of the metal composition. These ceramics are based on leucite-forming glasses, some of which are produced from naturally sourced, raw feldspar materials. Given their composition, they demonstrate excellent chemical resistance. With the corresponding mixture and targeted heat treatment of these glasses, leucite crystals with a defined grain size distribution are released in the glass matrix. This gives the veneering material a homogeneous structure, which is not only extremely gentle to antagonists, but also provides the high strength and convincing optical properties of the IPS InLine veneering ceramic materials.

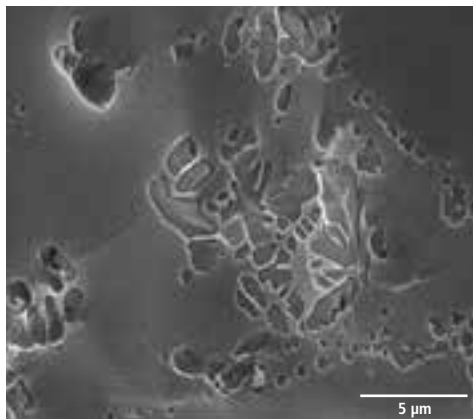

Indications

- One-layer veneering ceramic for the most popular dental alloys in the CTE range of $13.8\text{--}15.0 \times 10^{-6}/\text{K}$ (25–500°C) (IPS InLine One)
- Conventional multi-layer veneering ceramic for the most popular dental alloys in the CTE range of $13.8\text{--}15.0 \times 10^{-6}/\text{K}$ (25–500°C) (IPS InLine)
- Veneers on refractory die material (only IPS InLine)
- Characterization with IPS Ivocolor Shade and Essence
- Glazing with IPS Ivocolor Glaze

Contraindications

- If patients are known to be allergic to any of the constituents.
- Bruxism
- Veneering of titanium and zirconium oxide frameworks
- Any other uses not listed in the indications

Important processing restrictions

- Exceeding or falling short of the stipulated veneering layer thicknesses
- Failure to observe the layer thickness ratio between the framework and layering ceramics
- Mixing with and processing in conjunction with other dental ceramics
- Veneering of dental alloys not within the stipulated CTE range
- Failure to observe the necessary minimum connector and framework thicknesses

Side effects

If patients are known to be allergic to any of the constituents in the materials, IPS InLine One and IPS InLine restorations should not be used.

IPS InLine® PoM – Press-on-Metal Ceramic

Material

The IPS InLine PoM ingots are made of a glass-ceramic material containing leucite and based on synthetic glass raw materials, which contain small quantities of an opalescent glass-ceramic and translucent components. This gives the pressed, full-contour ingot a highly esthetic appearance. The ingot's shade is achieved with colour pigments. These pigments are temperature stable and therefore ensure of reliable shades in the pressed restoration. Both in their pressed and unpressed condition, the ingots demonstrate an isotropic structure, which is responsible for their homogeneous distribution of the leucite crystals and the high strength. Another important feature of IPS InLine PoM is its excellent firing stability, which enables the application of Touch-Up materials, Essence, Shades, Stains and Glaze without jeopardizing the fitting accuracy of the restoration. The Touch Up materials are leucite glass-ceramics shaded according to the ingot shade concept. Their thermal expansion and firing temperature are adjusted to suit application in the cervical area of the ingot after pressing and before the characterization firing cycles.

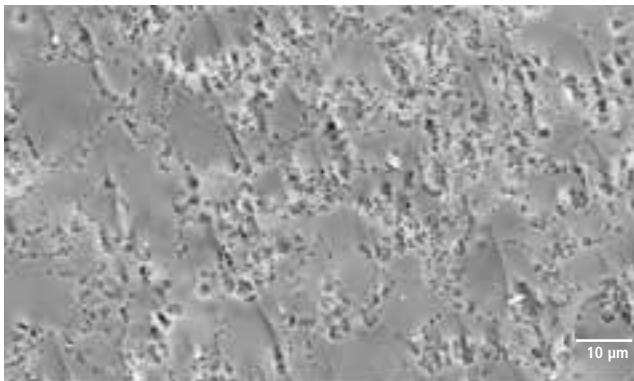

Indications

- Fully anatomical pressing on masked (opaqued) crown and bridge metal frameworks
- Pressing on dental alloys with a CTE range of $13.8 - 14.5 \times 10^{-6}/K$ (25–500°C) with a silver content of <10%
- Characterization with IPS Ivocolor Shade and Essence
- Glazing with IPS Ivocolor Glaze

Contraindications

- Pressing on dental alloys with a CTE outside the stipulated range and material composition
- Alloys with a silver (Ag) content higher than 10%.
- If patients are known to be allergic to any of the ingredients, the material should not be used.
- Pressing on titanium and zirconium oxide frameworks
- Very deep subgingival preparations
- Patients with severely reduced residual dentition
- Bruxism
- Any other uses not listed in the indications

Important processing restrictions

- Exceeding or falling short of the stipulated layer thicknesses for press ceramics
- Failure to observe the layer thickness ratio between the framework and layering ceramics
- Failure to observe the necessary minimum connector and framework thicknesses
- Layering with IPS InLine One / IPS InLine layering materials (e.g. Denticisal, Dentin, Incisal, Deep Dentin, Margin, Impulse and Gingiva materials, etc.)
- Mixing with and processing in conjunction with other dental ceramics
- Pressing over dental alloys outside of the stipulated CTE range

Side effects

If patients are known to be allergic to any of the components in the materials, IPS InLine PoM should not be used.

Warnings

- Hexane is highly flammable and detrimental to health. Avoid contact of the material with skin and eyes. Do not inhale vapours. Keep away from sources of ignition.
- Avoid inhaling grinding dust when working on ceramic restorations. Use suction equipment and protective masks.

Properties

Properties of IPS InLine® and IPS InLine® One according to ISO 6872:2015 and ISO 9693-1:2012

IPS InLine and IPS InLine One are classified as dental ceramics of Type I and Class I.

Material	CTE Ø (25–500 °C) [10 ⁻⁶ /K]	Glass transition temp. TG [°C]	Chem. solubility [µg/cm ²]	Flexural strength [MPa]	
	Specification	Specification	Specification	Specification	Typ. mean value
IPS InLine Paste Opaquer ¹⁾	13.6 ± 0.5	605 ± 20	< 100	≥ 50	170
IPS InLine Dentin ²⁾	12.8 ± 0.5	580 ± 20	< 100	≥ 50	89
IPS InLine Opal Effect	13.1 ± 0.5	595 ± 20	< 100	≥ 50	90
IPS InLine Add-On Margin	13.5 ± 0.5	585 ± 20	< 100	≥ 50	94
IPS InLine Add-On ³⁾	12.6 ± 0.5	455 ± 20	< 100	≥ 50	92
IPS InLine Add-On 690°C ³⁾	13.0 ± 0.5	440 ± 20	< 100	≥ 50	108

CTE 2x: Coefficient of thermal expansion after 2 firing cycles, CTE 4x: Coefficient of thermal expansion after 4 firing cycles, CTE Ø: Average value of CTE 2x and CTE 4x

¹⁾ Specifications apply to Paste Opaquer, Intensive Opaquer, Opaquer F

²⁾ Specifications apply to Dentin, Deep Dentin, Incisal, Transpa Incisal, One Denticisal, Transpa, Occlusal Dentin, Cervical Dentin, Cervical Incisal, Mamelon Gingiva, Intensive Gingiva

³⁾ The CTE is for a temperature range of 25 to 400°C.

⁴⁾ N/A: Not applicable

Properties of IPS InLine® PoM according to ISO 6872:2015 and ISO 9693-1:2012

IPS InLine PoM is classified as dental ceramic of Type II and Class 1.

Material	CTE Ø (25–500 °C) [10 ⁻⁶ /K]	Glass transition temp. TG [°C]	Chem. solubility [µg/cm ²]	Flexural strength [MPa]	
	Specification	Specification	Specification	Specification	Typ. mean value
IPS InLine PoM Touch Up	11.9 ± 0.5	545 ± 20	< 100	≥ 50	126
IPS InLine PoM Ingots	13.2 ± 0.5	575 ± 20	< 100	≥ 50	167

CTE 2x: Coefficient of thermal expansion after 2 firing cycles, CTE 4x: Coefficient of thermal expansion after 4 firing cycles, CTE Ø: Average value of CTE 2x and CTE 4x

¹⁾ Specifications apply to Paste Opaquer, Intensive Opaquer, Opaquer F

²⁾ Specifications apply to Dentin, Deep Dentin, Incisal, Transpa Incisal, One Denticisal, Transpa, Occlusal Dentin, Cervical Dentin, Cervical Incisal, Mamelon Gingiva, Intensive Gingiva

³⁾ The CTE is for a temperature range of 25 to 400°C.

⁴⁾ N/A: Not applicable

Coordinated Ivoclar Vivadent alloys

IPS InLine® One, IPS InLine® ...

are suitable for alloys with a CTE of approximately 13.8 to $15.0 \times 10^{-6}/K$ at $25-500^{\circ}C$. If the required framework design with metal collars (as described on page 25) and the ceramic layer thickness of max. 1.5 mm are observed, these alloys may be processed using **standard cooling** in the Ivoclar Vivadent Programat® furnaces.

IPS InLine® PoM ...

is suitable for pressing on alloys with a CTE of 13.8 to $14.5 \times 10^{-6}/K$ at $25-500^{\circ}C$ and with a maximum silver content of 10% .



Alloy	IPS InLine One IPS InLine	IPS InLine PoM IPS Investment Ring 100/200 g	IPS InLine PoM IPS Investment Ring 300 g	Colour
High gold				
Brite Gold	✓*			rich yellow
Brite Gold XH	✓*			rich yellow
Golden Ceramic	✓*			rich yellow
Callisto 86	✓	✓	✓	rich yellow
Aquarius Hard	✓*	✓ ²⁾	✓ ²⁾	rich yellow
Aquarius	✓*			rich yellow
d.SIGN 98	✓*	✓ ¹⁾		rich yellow
Callisto 84	✓	✓	✓	rich yellow
Y	✓			yellow
Aquarius XH	✓	✓	✓	yellow
Y-2	✓*			yellow
Y-Lite	✓	✓	✓	yellow
Sagittarius	✓	✓	✓	white
Y-1	✓*			yellow
d.SIGN 96	✓	✓		yellow
BioPorta G	✓	✓		yellow
Porta Reflex	✓	✓	✓	yellow
Porta P6	✓	✓	✓	white
Porta Geo Ti	✓	✓		yellow
Reduced gold				
d.SIGN 91	✓	✓	✓	white
W	✓	-	-	white
W-5	✓	-	-	white
Lodestar	✓	✓	✓	white
W-3	✓	✓	✓	white
Leo	✓	✓	✓	white
W-2	✓	✓	✓	white
Porta Imuls	✓	✓		light yellow
Porta SMK 82	✓	✓	✓	white
Euro 45	✓			white
Palladium content				
Capricorn	✓	✓	✓	white
d.SIGN 84	✓	✓ ²⁾	✓ ²⁾	white
Protocol	✓	✓ ²⁾	✓ ²⁾	white
Callisto 75 Pd	✓	✓	✓	white
Aries	✓	-	-	white
d.SIGN 67	✓	-	-	white
d.SIGN 59	✓*	-	-	white
d.SIGN 53	✓**	-	-	white
W-1	✓*	-	-	white
Capricorn 15	✓	-	-	white
Callisto CPG	✓	✓	✓	white
Simidur S2	✓	✓		white
Duo Pal 6	✓	✓	✓	white
Simidur S1S	✓			white
Simidur Reflex LC	✓			white

Alloy	IPS InLine One IPS InLine	IPS InLine PoM IPS Investment Ring 100/200 g	IPS InLine PoM IPS Investment Ring 300 g	Colour
Implant alloys				
Callisto Implant 78	✓	✓	✓	white
Callisto Implant 33	✓	✓	✓	white
IS-64	✓**	–	–	white
Callisto Implant 60	✓**	–	–	white
Porta Implant	✓	✓	✓	white
Euro 33 Implant	✓			white
Base metal				
Colado NC	✓	✓	✓	white
4all	✓	✓ 2)	✓ 2)	white
d.SIGN 30	✓**	✓ 2)	✓ 2)	white
Colado CC	✓**	✓ 2)	✓ 2)	white
For CAD/CAM				
Base metal				
Colado® CAD CoCr4	✓	✓	✓	white



 **Original WIELAND Dental Alloy**

✓ recommended product combinations

* Cooling to 800°C / 1472°F
** Cooling to 700°C / 1292°F

1) Single restorations
2) See "Important"

The range of available alloys may vary from country to country.

Important

IPS InLine® One, IPS InLine®

- If these minimum requirements cannot be observed, cooling to *800°C (1472°F), or **700 °C (1292°F) is required in conjunction with all main firings and glaze firings.
- With ceramic layer thicknesses of over 1.5 mm up to max. 2.5 mm, as well as with voluminous restorations (e.g. implant-retained reconstructions) in combination with high gold and base metal alloys, cooling to *800°C (1472°F) or ** 700°C (1292°F) must be conducted. This also applies to soldered restorations.

Important

IPS InLine® PoM

- With alloys in the lower CTE range of $13.8 \times 10^{-6}/K$ at 25–500 °C and the upper range of $14.5 \times 10^{-6}/K$ at 25–500°C, no ceramic shoulders should be used. With such framework geometries (shoulder) or non-metal-supported areas, the cooling and tension conditions are critical. For ceramic shoulders, alloys in the CTE range of approximately 14.0 to $14.3 \times 10^{-6}/K$ at 25–500°C are recommended.
- For single restorations – particularly with ceramic shoulders – only the 200g or 300g investment rings should be used, since the expansion values as well as the cooling and tension conditions are ideally coordinated.

Preparation guidelines and minimum thicknesses

The preparation must provide sufficient space to achieve stable and esthetic metal-ceramic restorations.

For the IPS InLine veneering ceramic, the usual preparation guidelines for metal-ceramics apply. As usual for metal-supported restorations, dentists may use conventional cementation.

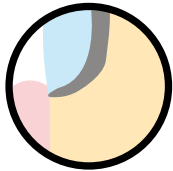

A chamfer preparation is suitable for tapered metal margins.

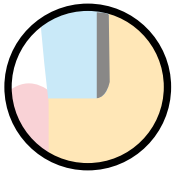

For esthetically pleasing single crowns and bridge abutment crowns, a ceramic shoulder should be provided. For that purpose, a shoulder preparation is required. If adhesive cementation is used, the restoration margin can be in ceramic. However, the margin should not be bevelled in such cases, since tapering, non-metal-supported margins demonstrate a fracture risk.

IPS InLine One One-layer metal-ceramic	IPS InLine Conventional metal-ceramic	IPS InLine PoM Press-on-Metal ceramic
Minimum dimensions for metal frameworks: <ul style="list-style-type: none"> – Crowns min. 0.3 mm – Abutment crowns min. 0.5 mm 	Minimum dimensions for metal frameworks: <ul style="list-style-type: none"> – Crowns min. 0.3 mm – Abutment crowns min. 0.5 mm 	Minimum dimensions for metal frameworks: <ul style="list-style-type: none"> – Crowns min. 0.3 mm – Abutment crowns min. 0.5 mm
Minimum ceramic layer thickness: <ul style="list-style-type: none"> – IPS InLine One min. 0.8 mm 	Minimum ceramic layer thickness: <ul style="list-style-type: none"> – IPS InLine min. 0.8 mm 	Minimum ceramic layer thickness: <ul style="list-style-type: none"> – IPS InLine PoM min. 0.8 mm

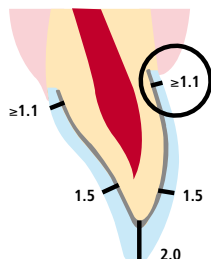
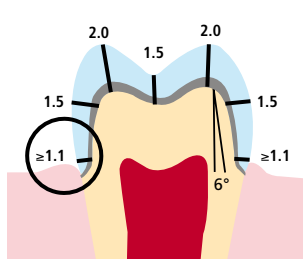

Example of a preparation
Dimensions in mm

Minimum dimensions for metal frameworks:

- Crowns min. 0.3 mm
- Abutment crowns min. 0.5 mm

Minimum ceramic layer thickness:

- IPS InLine min. 0.8 mm

- With conventional cementation, a minimum height of 3 mm of the prepared tooth and a convergence angle of approx. 6° must be observed.
- The minimum connector dimensions must be observed for bridge restorations. The connector dimensions depend on the selected alloy and the pontic width (see framework design criteria).

Veneers on refractory dies

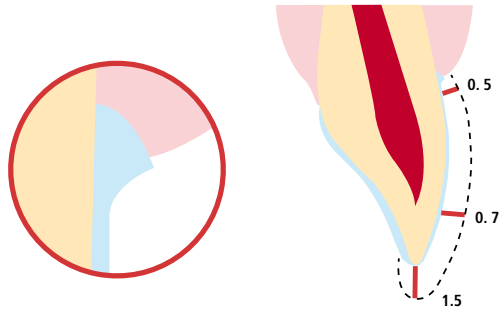

Example of a preparation
Dimensions in mm

- If possible, the preparation for veneers should be entirely in the enamel. The incisal preparation margins should not be located in the area of the abrasion surfaces or dynamic occlusal surfaces. Prepare a chamfer in the cervical area.
- Observe the required minimum layer thickness (see illustration).

IPS InLine® One – One-Layer Metal-Ceramic

Framework design criteria

The framework design is key to the success of durable metal-ceramic restorations. The more attention given to the framework design, the better the final results and the clinical success will turn out to be.

Functional support of the veneering ceramic

The framework reflects the shape of the tooth in a reduced form. It should be designed in such a way that it supports the cusps and incisal edges resulting in a virtually even layer thickness of the veneering ceramic in the cusp-fissure area. In this way, the masticatory forces occurring during functional chewing are exerted on the framework rather than on the veneering ceramic. Therefore, the framework must not show any angles and edges (see diagram) so that the masticatory forces do not result in tension peaks, which may cause delamination and cracks. Any sharp angles or edges should be removed in the wax-up rather than grinding the metal framework. The wall thickness of the metal framework for single crowns must not be less than 0.3 mm and for bridge abutments 0.5 mm after finishing (see diagram). For further information, please refer to the Instructions for Use of the corresponding alloy.

Anterior crowns

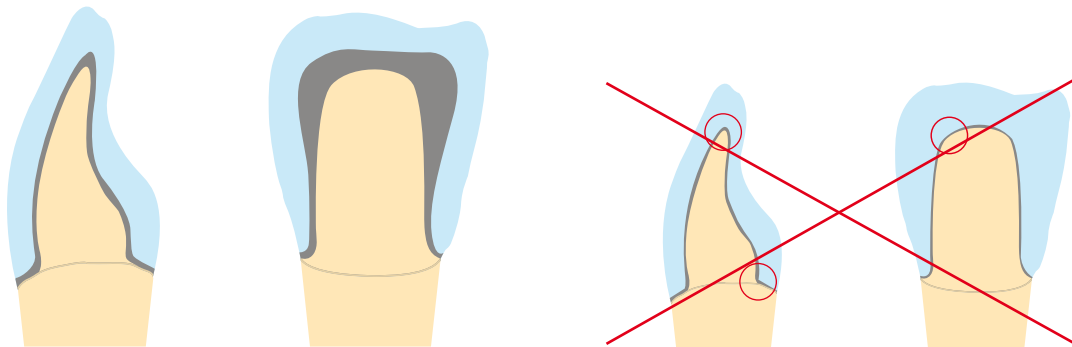

Premolar crowns

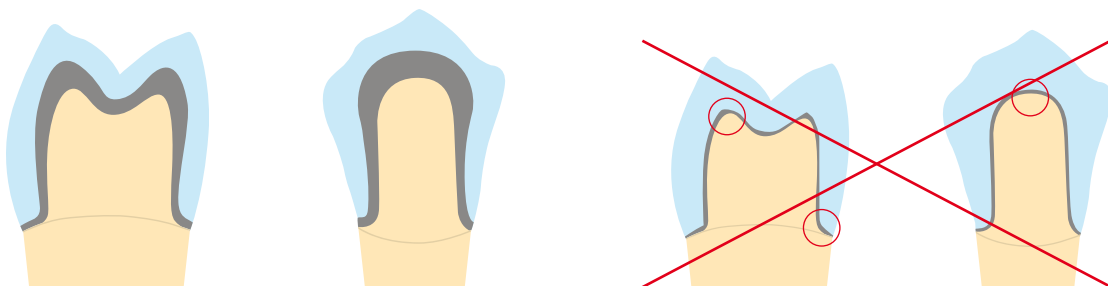

Molar crowns

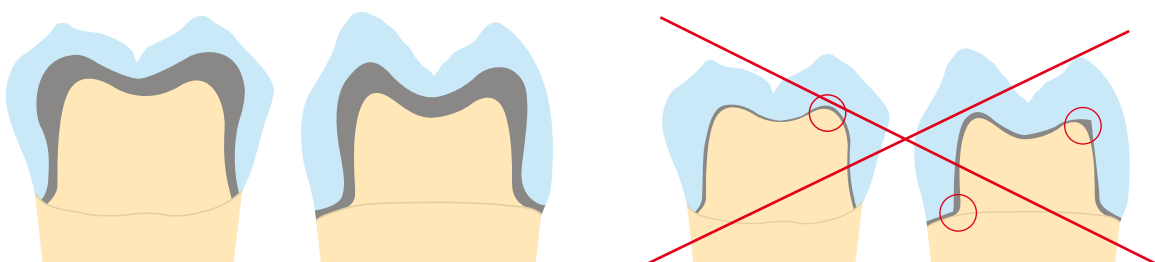

Framework design for fired ceramic shoulders

With fused ceramic shoulders, make sure that the framework rather than the veneer is supported by the prepared tooth. The framework is thus reduced exactly to the inner edge of the chamfer or shoulder preparation. In this way, functional support of the framework on the preparation is achieved. Excellent fitting accuracy on the preparation is essential to ensure that the shoulder material may not reach the inner aspects of the framework during subsequent application.

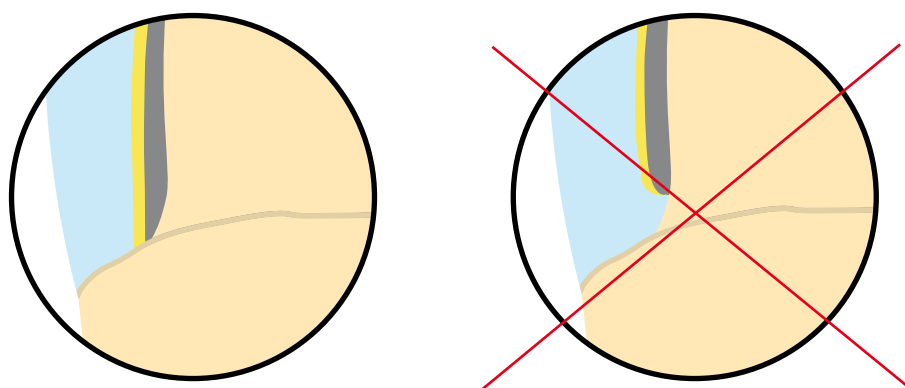

Framework stability

The dimensions and shape of the interdental connector surfaces decisively influence the stability of the restoration during processing, as well as the clinical long-term success after incorporation. Therefore, the dimensions of the interdental connector surface must be designed in accordance with the alloy used (take the 0.2% proof stress into account)! The thermal behaviour of the selected alloy during processing has to be considered when designing the framework.

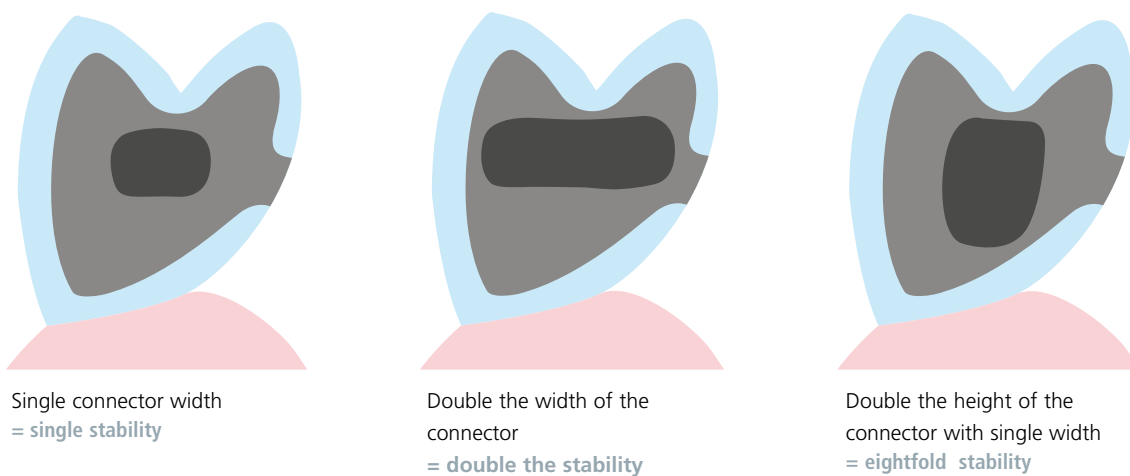

Framework design for bridges

Thermal stress during firing and masticatory forces after cementation affect metal frameworks. Therefore, these forces must be transferred to the framework rather than the veneer. Particularly in the connector areas between bridge abutments and bridge pontics in bridge reconstructions, the stability must be ensured with the help of the framework design and adequate framework material thickness. The framework design and framework thickness must therefore meet all the optical and functional requirements, as well as the aspects of periodontal hygiene. A full wax-up with the corresponding reduction of the ceramic provides the best restoration framework.

During veneering with ceramic materials, the bridge framework is exposed to high temperatures several times. With an inappropriate framework design or insufficient framework thickness, the high temperatures during firing may result in distortion or inaccuracy of fit of the framework. A collar margin design with e.g. interproximal reinforcements, counteracts this development. Additionally, this framework design (e.g. with cooling grooves) ensures more even cooling of the restoration during the cooling phase. This is particularly important if high gold alloys are used.

In order to enable optimum oral hygiene with bridge restorations, the design of the interdental spaces should be given special attention. Adequate opening of the interdental area without creating black triangles should be factored in when designing the framework in order to ensure proper periodontal hygiene with interdental brushes and dental floss.

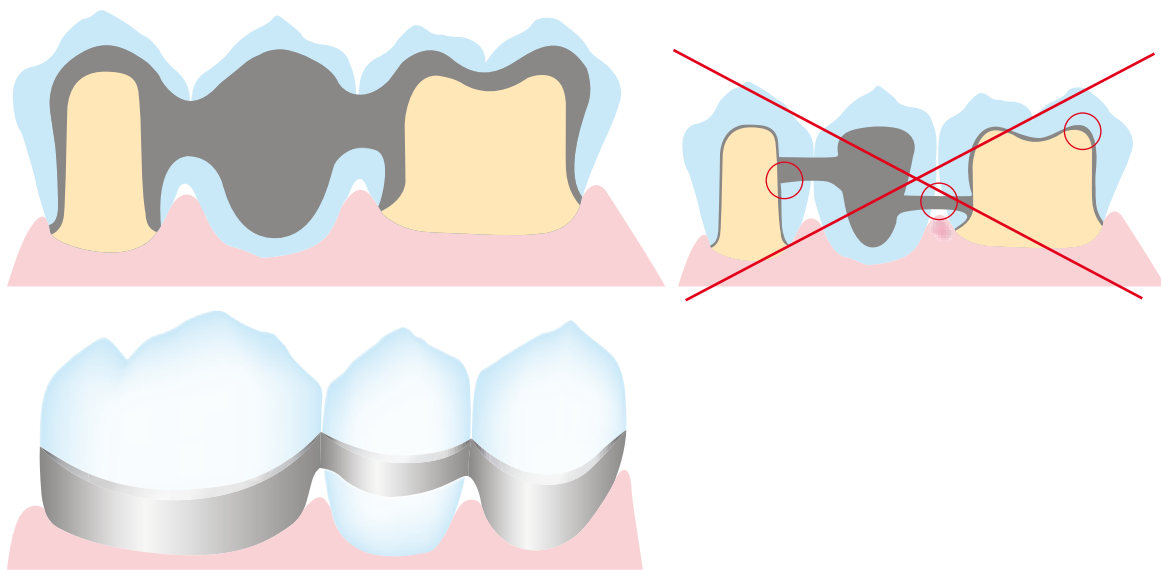

Design of bridge pontics

Bridge pontics are designed taking esthetic and functional aspects into account, as well as oral hygiene. The area of the pontic that contacts the alveolar ridge should be made of ceramic.

In order to ensure adequate stability between the bridge pontic and the bridge abutments, a palatal and/or lingual collar is recommended. Furthermore, to ensure even cooling of the bridge pontic that absorbs the most heat, additional cooling grooves are advantageous.

**Bridge pontic design –
ovate pontic**



**Bridge pontic design –
saddle-type pontic**

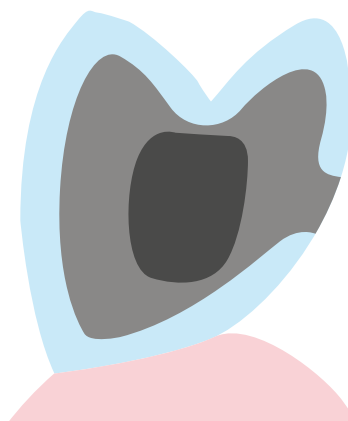

Transition between metal and ceramic

The transition between the metal framework and the veneering ceramic must be clearly defined. If possible, incorporate a right angle finish line. The junctures between the metal framework and the veneering ceramic must not be located in the contact area nor on surfaces involved in masticatory functions. The transition in the interdental area should be designed in such a way that cleaning of these difficult-to-access areas is possible.

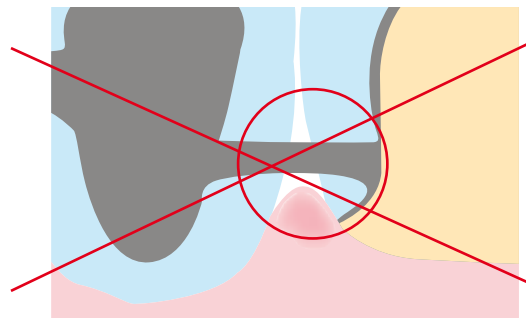
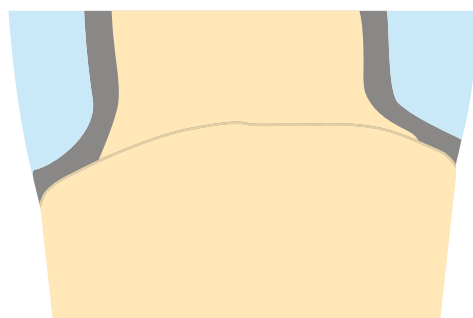
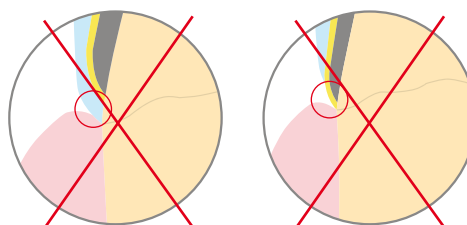
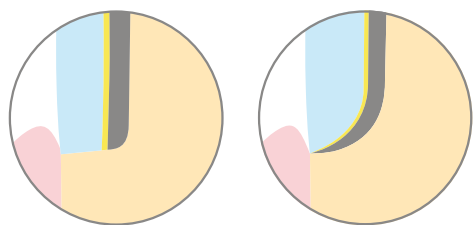

Holding pins

In order not to damage the crown wall during processing, the crown and bridge frameworks are provided with holding pins. They are directly attached to the framework with the help of wax. Dimensions of \varnothing 0.5–1.0 mm for the holding pins have proven to be useful. They can be used to secure the framework by means of holding clips. Furthermore, the holding pins also act as cooling grooves during casting and firing.



The holding pins must be placed in such a way that they do not interfere during try-in or in the articulator. They should only be removed without causing overheating once the restoration has been completed.



Please refer to the "Framework Design Manual for Metal-Ceramic Restorations" for additional information on framework design. They can be ordered from your Ivoclar Vivadent contact address.

Step-by-step procedure

Starting situation



Maxillary and mandibular model articulated in the "Stratos 200"



Starting situation for metal-supported IPS InLine restorations

Framework design

Design the framework with a reduced anatomical shape taking the planned layering into account. The wall thickness of single crowns should be at least 0.3 mm and at least 0.5 mm for abutment crowns.

Make sure to provide sufficient stability of shape for the framework. Avoid sharp transitions and edges. Design the connector areas between the individual units in such a stable way that they meet the requirements for interdental hygiene and the alloy used.



Design the framework in a reduced supported shape.



Alloy processing / oxide firing

The cast metal framework is finished using tungsten carbide metal burs or ceramic-bonded grinding instruments.



Framework before processing / before blasting



Carefully blast the framework with aluminium oxide Al_2O_3 50–100 μm (observe the instructions of the alloy manufacturer).



After blasting, clean the metal framework with a steam jet and allow to dry thoroughly. Conduct the oxide firing according to the instructions of the manufacturer.

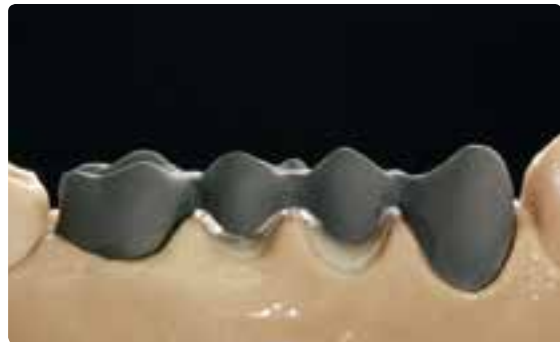

After oxide firing, the framework should exhibit an evenly oxidized surface.

Layering diagram IPS InLine® One

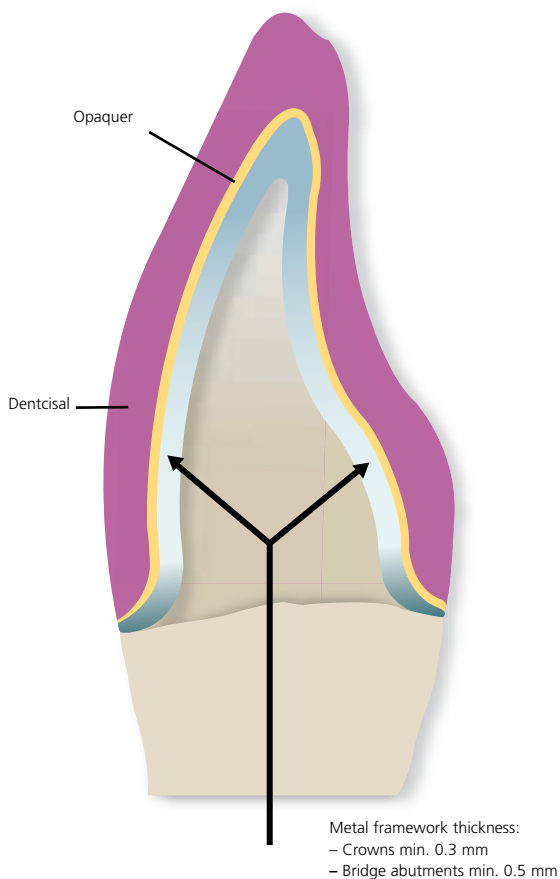

	Ideal layer thickness	Limited layer thickness
Framework	0.3-0.5 mm	0.3-0.5 mm
Opaquers	0.1 mm	0.1 mm
Dentceral		
Cervical	0.8 mm	0.5 mm
Incisal	1.5 mm	0.8 mm

These figures are drawn from past experience and they may vary in certain situations.

Note:

To enhance the chroma in thin layers, IPS InLine Deep Dentin in the corresponding opaquer shade may be thinly applied on the opaquer.

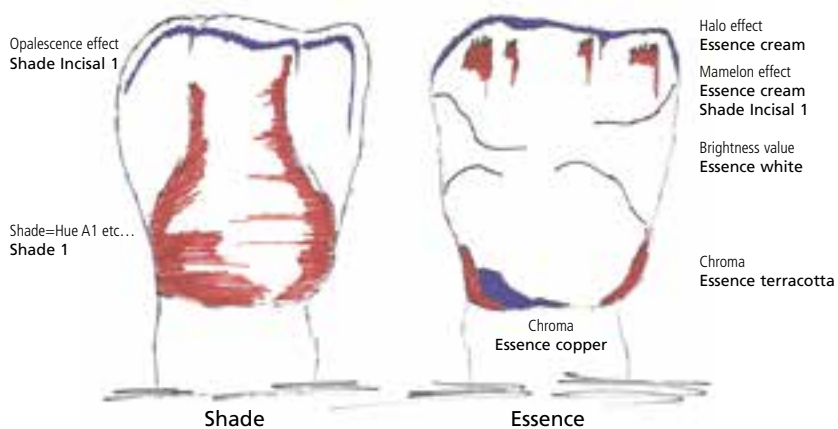

Depending on the desired individualization, IPS Ivocolor Essence / Shades can be used to achieve true-to-nature shade effects.

Opaquer firing

Paste opaquer

1st Opaquer firing (wash firing), (paste opaquer)

Select the IPS InLine System Opaquer paste in the corresponding tooth shade. If required, homogenize the opaquer paste by agitating it before taking it from its container. Extrude the desired amount from the syringe or jar and mix thoroughly on the mixing pad. Dilute it, if required. Apply the first opaquer layer thinly and agitate it into the alloy surface. After firing and cooling, clean the opaqued metal framework with the steam jet and subsequently dry with oil-free air.



The consistency of the paste opaquer can be individually adjusted using the IPS InLine System Opaquer Liquid.

2nd Opaquer firing (paste opaquer)

Apply the 2nd opaquer layer in an even, covering layer. After firing, the IPS InLine System Opaquer should show a covering, silky-mat shiny surface. After the opaquer firing, the conditioned surfaces of the alloy should be entirely covered with opaquer.



The firing tray with the opaqued metal framework should only be placed in the firing chamber and removed from it once the furnace head is completely open and the beeper has sounded.



Firing parameters for the 1st and 2nd Opaquer firing see page 68.

1st Dencisal firing

Isolate the model before layering the Dencisal material. In this way, the ceramic material is prevented from drying out or sticking to the model respectively. Isolate the stone die and the adjacent areas using IPS Model Sealer. Additionally, separate the area of the pontics with IPS Ceramic Separating Liquid.



To achieve an optimum bond between the ceramic material and the opaquer surface, apply a small amount of IPS InLine One Dencisal material to the cervical and interdental areas (for bridges) and slightly roughen it.

Make sure that the restoration is slightly overcontoured so that the actual tooth shape is achieved after firing. After lifting the bridge off the model, supplement the contact points with Dencisal materials. Before firing, separate the entire interdental area down to the opaquer.



Densify the ceramic surface (after contouring) with a large, dry brush toward the cervical margin before firing.



The ceramic material is applied according to the individual situation.



For an optimum firing result, the interdental areas must be separated down to the opaquer.



Fired restoration after the 1st Dencisal firing



- Use distilled water to rewet the mixed or even already applied layering material.
- The firing tray with the opaqued metal framework should only be placed in the firing chamber and removed from it once the furnace head is completely open and the beeper has sounded.



Firing parameters for the 1st Dencisal firing see page 68.

2nd Dencisal firing

Finish and thoroughly clean the restoration. Clean under running water or with the steam jet. Blasting the restoration with Al_2O_3 (50 μm) at 1 bar (15 psi) pressure is only necessary if there is superficial contamination after cleaning. Thoroughly dry the restoration and complete the missing areas. Pay special attention to interdental spaces as well as contact points. Place the completely layered restoration on the firing tray and ensure adequate support. The firing tray with the restoration should only be placed in the firing chamber once the furnace head is completely open and the beeper has sounded. Use the firing parameters stipulated below to fire the restoration.



Supplementing the restoration with Dencisal material



Final design of the occlusal surface



- Use distilled water to rewet the mixed or even already applied layering material.
- The firing tray with the opaqued metal framework should only be placed in the firing chamber and removed from it once the furnace head is completely open and the beeper has sounded.



Firing parameters 2nd Dencisal firing see page 68.

Individual finishing

Preparing for Stain and Glaze firing

Before the Stain and Glaze firing, the restoration has to be prepared as follows:

- Finish the restoration using diamonds and give it a true-to-nature shape and surface structure, such as growth lines and convex/concave areas.
- Areas which should exhibit a higher gloss after Glaze firing (e.g. pontic rests) can be smoothed out using silicone discs.
- If gold and/or silver dust was used to design the surface texture, the restoration has to be thoroughly cleaned with steam. Make sure to remove all gold or silver dust in order to avoid any discolouration after firing.



The true-to-nature shape and surface texture are designed.



Before the application of the glaze paste, the IPS InLine ceramic surface must not be too shiny. A too shiny ceramic surface will make the glazing paste run off into the crevices of the ceramic surface (e.g. interdental spaces). Slight blasting of the ceramic surface, e.g. with 50 µm aluminium oxide, promotes the wetting of the ceramic surface with glazing paste.



The further procedure for the Stain and Characterization firing as well as the Glaze firing are described in the chapter on completing the restoration (see page 62–66).



Individually designed and characterized bridge made of IPS InLine One.

IPS InLine® – Conventionally layered

Framework design criteria

The framework design is key to the success of durable metal-ceramic restorations. The more attention given to the framework design, the better the final results and the clinical success will turn out to be.

Functional support of the veneering ceramic

The framework reflects the shape of the tooth in a reduced form. It should be designed in such a way that it supports the cusps and incisal edges resulting in a virtually even layer thickness of the veneering ceramic in the cusp-fissure area. In this way, the masticatory forces occurring during functional chewing are exerted on the framework rather than on the veneering ceramic. Therefore, the framework must not show any angles and edges (see diagram) so that the masticatory forces do not result in tension peaks, which may cause delamination and cracks. Any sharp angles or edges should be removed in the wax-up rather than grinding the metal framework. The wall thickness of the metal framework for single crowns must not be less than 0.3 mm and for bridge abutments 0.5 mm after finishing (see diagram). For further information, please refer to the Instructions for Use of the corresponding alloy.

Anterior crowns

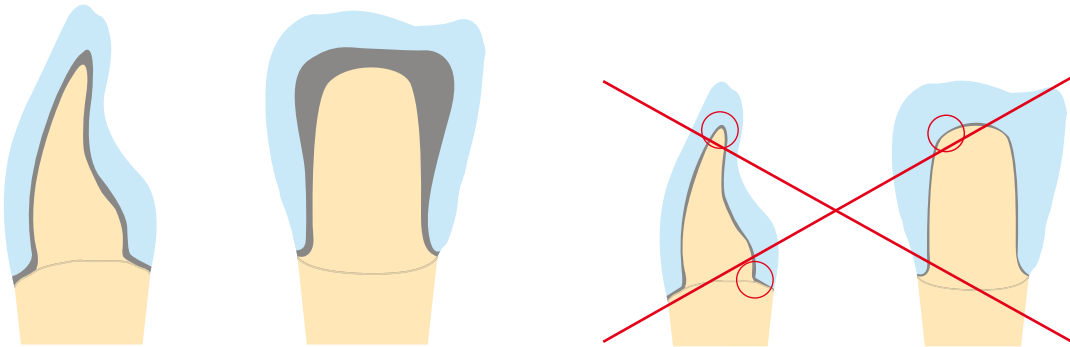

Premolar crowns

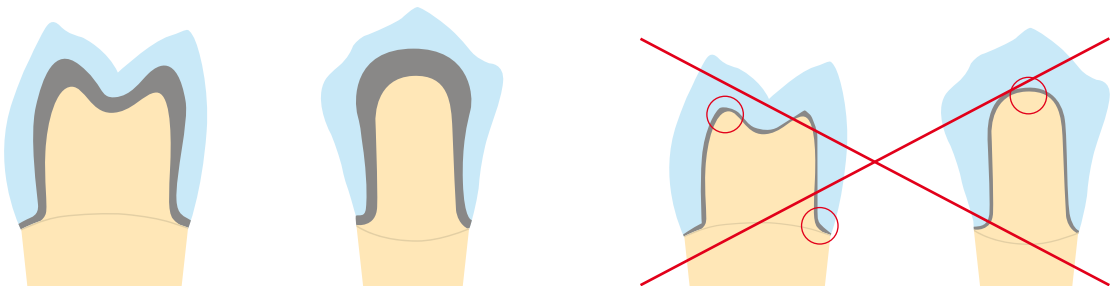

Molar crowns

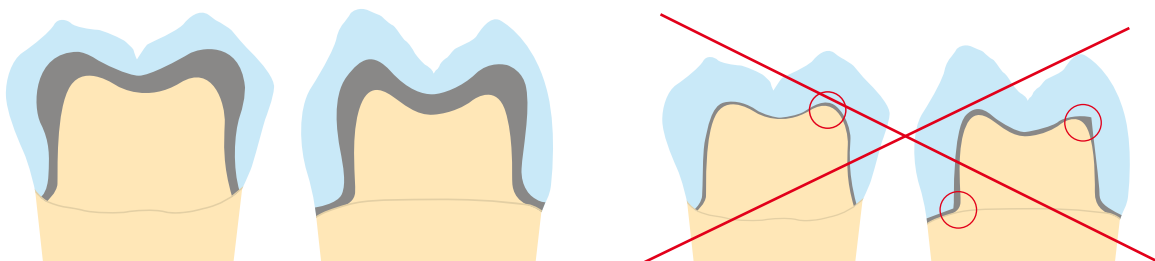

Framework design for fired ceramic shoulders

With fused ceramic shoulders, make sure that the framework rather than the veneer is supported by the prepared tooth. The framework is thus reduced exactly to the inner edge of the chamfer or shoulder preparation. In this way, functional support of the framework on the preparation is achieved. Excellent fitting accuracy on the preparation is essential to ensure that the shoulder material may not reach the inner aspects of the framework during subsequent application.

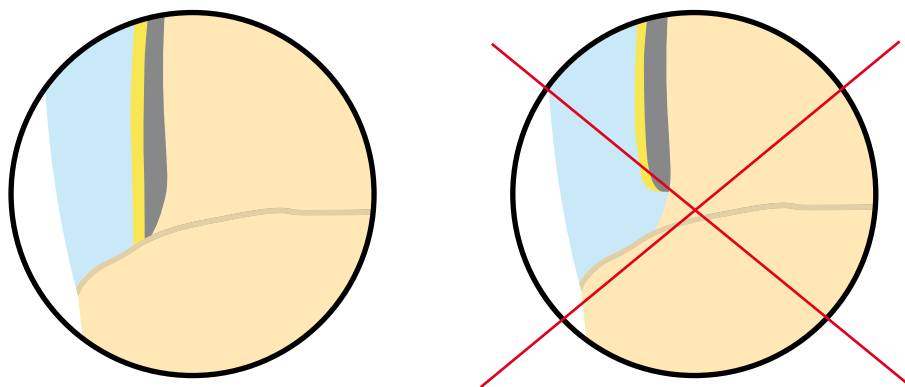

Framework stability

The dimensions and shape of the interdental connector surfaces decisively influence the stability of the restoration during processing, as well as the clinical long-term success after incorporation. Therefore, the dimensions of the interdental connector surface must be designed in accordance with the alloy used (take the 0.2% proof stress into account)! The thermal behaviour of the selected alloy during processing has to be considered when designing the framework.



Single connector width
= **single stability**

Double the width of the
connector
= **double the stability**

Double the height of the
connector with single width
= **eightfold stability**

Framework design for bridges

Thermal stress during firing and masticatory forces after cementation affect metal frameworks. Therefore, these forces must be transferred to the framework rather than the veneer. Particularly in the connector areas between bridge abutments and bridge pontics in bridge reconstructions, the stability must be ensured with the help of the framework design and adequate framework material thickness. The framework design and framework thickness must therefore meet all the optical and functional requirements, as well as the aspects of periodontal hygiene. A full wax-up with the corresponding reduction of the ceramic provides the best prerequisites.

During veneering with ceramic materials, the bridge framework is exposed to high temperatures several times. With an inappropriate framework design or insufficient framework thickness, the high temperatures during firing may result in distortion or inaccuracy of fit of the framework. A collar design with e.g. interproximal reinforcements, counteracts this development. Additionally, this framework design (e.g. with cooling grooves) ensures more even cooling of the restoration during the cooling phase. This is particularly important if high gold alloys are used.

In order to enable optimum oral hygiene with bridge restorations, the design of the interdental spaces should be given special attention. Adequate opening of the interdental area without creating black triangles should be factored in when designing the framework in order to ensure proper periodontal hygiene with interdental brushes and dental floss.

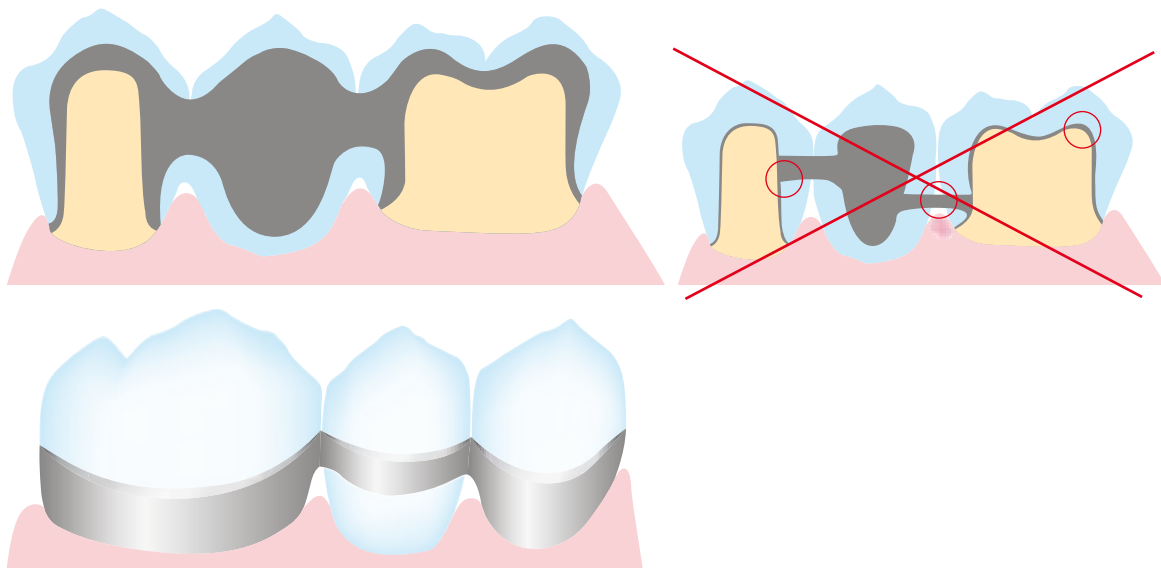

Design of bridge pontics

Bridge pontics are designed taking esthetic and functional aspects into account, as well as oral hygiene. The area of the pontic that contacts the alveolar ridge should be made of ceramic.

In order to ensure adequate stability between the bridge pontic and the bridge abutments, a palatal and/or lingual collar is recommended. Furthermore, to ensure even cooling of the bridge pontic that absorbs the most heat, additional cooling grooves are advantageous.

**Bridge pontic design –
ovate pontic**



**Bridge pontic design –
saddle-type pontic**

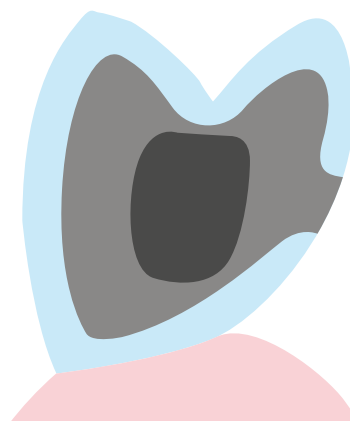

Interface between metal and ceramic

The interface between the metal framework and the veneering ceramic must be clearly defined. If possible, incorporate a right angle finish line. The junctures between the metal framework and the veneering ceramic must not be located in the contact area nor on surfaces involved in masticatory functions. The interface in the interdental area should be designed in such a way that cleaning of these difficult-to-access areas is possible.

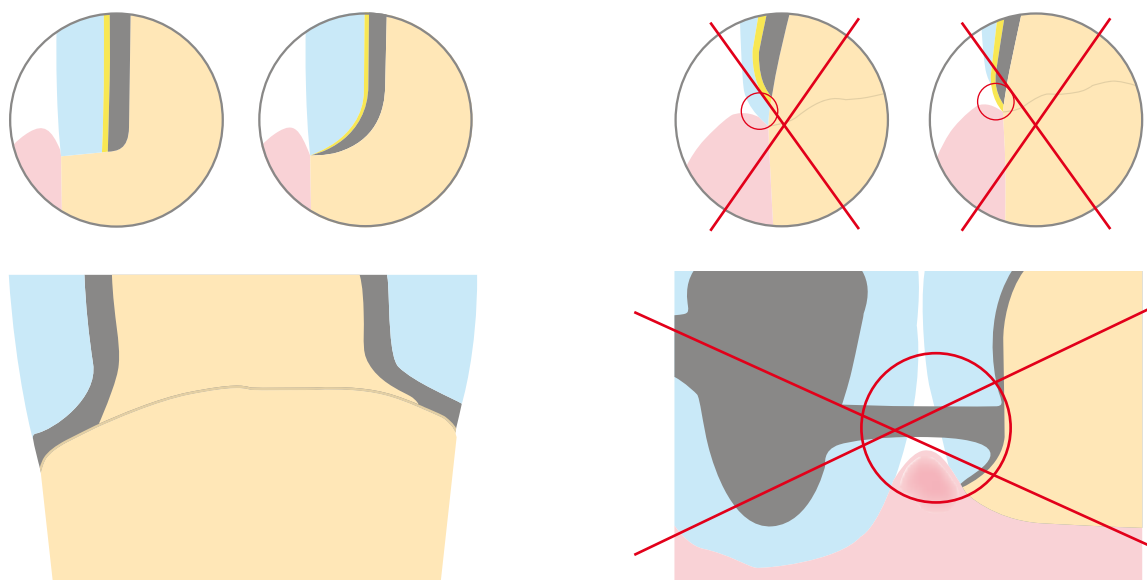

Holding pins

In order not to damage the crown wall during processing, the crown and bridge frameworks are provided with holding pins. They are directly attached to the framework with the help of wax. Dimensions of Ø 0.5–1.0 mm for the holding pins have proven to be useful. They can be used to secure the framework by means of holding clips. Furthermore, the holding pins also act as cooling grooves during casting and firing.



The holding pins must be placed in such a way that they do not interfere during try-in or in the articulator. They should only be removed without causing overheating once the restoration has been completed.



Please refer to the "Framework Design Manual for Metal-Ceramic Restorations" for additional information on framework design. They can be ordered from your Ivoclar Vivadent contact address.

Step-by-step procedure

Starting situation



Maxillary and mandibular model articulated in the "Stratos 200"



Starting situation for metal-supported IPS InLine restorations

Framework design

Design the framework with a reduced anatomical shape taking the planned layering into account. The wall thickness of single crowns should be at least 0.3 mm and at least 0.5 mm for abutment crowns.

Make sure to provide sufficient stability of shape for the framework. Avoid sharp transitions and edges. Design the connector areas between the individual units in such a stable way that they meet the requirements for interdental hygiene and the alloy used.



Design the framework in a reduced supported shape.

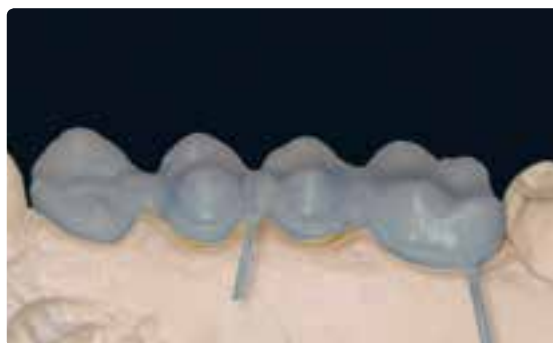

Alloy processing / oxide firing

The cast metal framework is finished using tungsten carbide metal burs or ceramic-bonded grinding instruments. To make room for the ceramic shoulder (labial or circular), the marginal area of the framework is reduced up to the inner edge of the chamfer or shoulder preparation.



Surface finishing before blasting.



Carefully blast the framework with aluminium oxide Al_2O_3 , 50–100 μm (observe the instructions of the alloy manufacturer).



After blasting, clean the metal framework with a steam jet and allow to dry thoroughly. Conduct the oxide firing according to the instructions of the manufacturer.

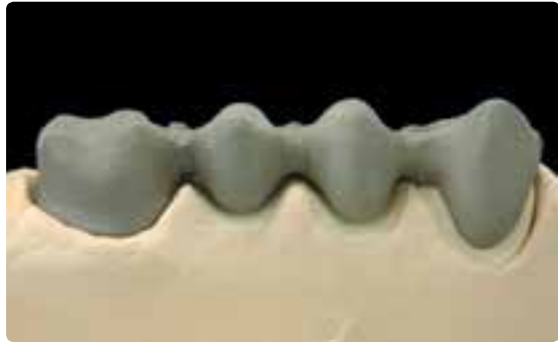

After oxide firing, the framework should exhibit an evenly oxidized surface.

Layering diagram IPS InLine®

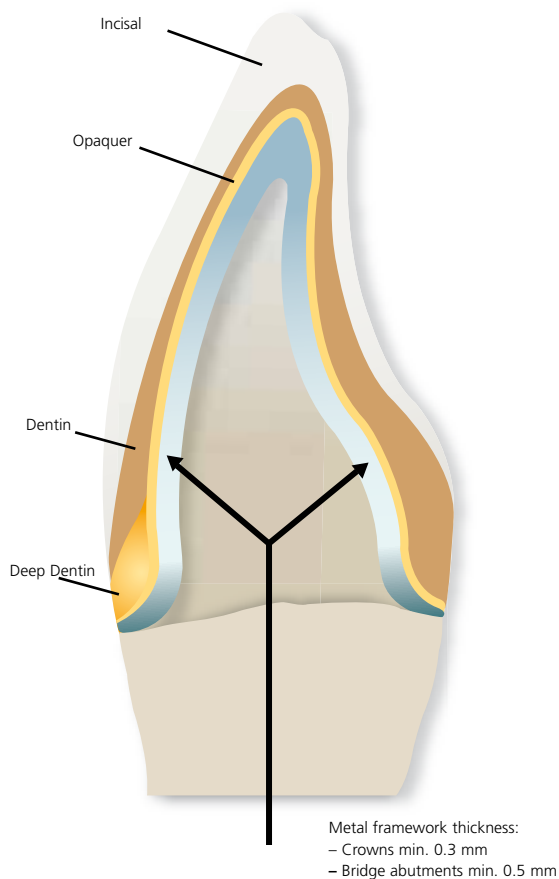

	Ideal layer thickness	Limited layer thickness
Framework	0.3–0.5 mm	0.3–0.5 mm
Opaquer	0.1 mm	0.1 mm
Deep Dentin		
Cervical	–	0.3 mm
Incisal	–	0.1 mm
Dentin		
Cervical	1 mm	0.5 mm
Incisal	0.7 mm	0.3 mm
Incisal		
Cervical	0.2 mm	0.1 mm
Incisal	0.5 mm	0.4 mm

These figures are drawn from past experience and they may vary in certain situations.

Depending on the clinical situation or the selected shade system (Chromascop, A–D, and Bleach), various components may be used to achieve the targeted shade effects.

The Incisal materials in A–D shades are applied up to the centre of the cervical third.

With Chromascop shades, the Incisal materials are only layered up to the beginning of the cervical third.

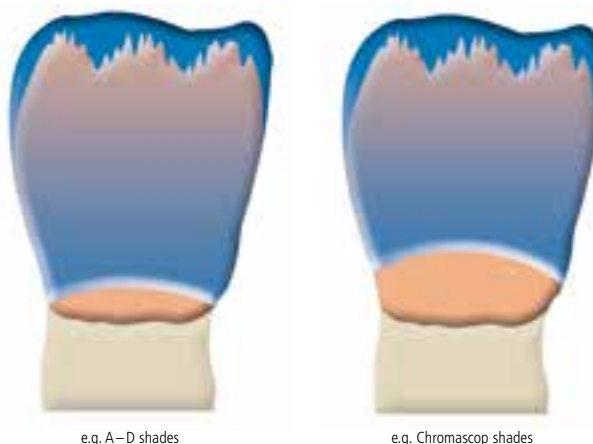

e.g. A–D shades

e.g. Chromascop shades

Opaquer firing

Paste opaquer

1st Opaquer firing (wash firing), (paste opaquer)

Select the IPS InLine System Opaquer paste in the corresponding tooth shade. If required, homogenize the opaquer paste by agitating it before taking it from its container. Extrude the desired amount from the syringe or jar and mix thoroughly on the mixing pad. Dilute it, if required. Apply the first opaquer layer thinly and agitate it into the alloy surface. After firing and cooling, clean the opaqued metal framework with the steam jet and subsequently dry with oil-free air.



The consistency of the paste opaquer can be individually adjusted using the IPS InLine System Opaquer Liquid.

2nd Opaquer firing (paste opaquer)

Apply the 2nd opaquer layer in an even, covering layer. After firing, the IPS InLine System Opaquer should show a covering, silky-mat shiny surface. After the opaquer firing, the conditioned surfaces of the alloy should be entirely covered with opaquer.



The firing tray with the opaqued metal framework should only be placed in the firing chamber and removed from it once the furnace head is completely open and the beeper has sounded.



Firing parameters for the 1st and 2nd Opaquer firing see page 69.

IPS InLine® System Opaquer F

The Opaquer F can be used to reinforce the in-depth fluorescence.

- **Either:** Apply the Opaquer F as a thin, **third** opaquer layer and fire (930 °C/1706 °F).
- **or:** Mix up to 20% of Opaquer F with the conventional IPS InLine System Opaquer before the second layer is applied and fire at 930 °C/1706 °F.



1st + 2nd Margin firing

A ceramic shoulder can be fabricated on the metal framework after the opaquer firing, if the necessary space has been provided during finishing. Before creating the ceramic shoulder, seal the stone die with IPS Margin Sealer and then, after drying, with IPS Ceramic Separating Liquid.

After that, the IPS InLine Margin material in the respective shade is generously applied in drop-shaped increments in the cervical area (i.e. the outer surface of the ceramic is given a convex design) and dried. Then, carefully remove the framework with the dried shoulder material from the die.



When designing a ceramic shoulder (particularly for bridges), the Margin material may be applied slightly higher up in the proximal area. This will reduce the interdental shrinkage during the subsequent Dentin and Incisal firings.



After firing, the shoulder may have to be slightly adjusted by grinding in order to remove any interfering areas. Subsequently, the fitting accuracy (sinter shrinkage) of the shoulder has to be optimized with a 2nd Margin firing. Use the same Margin materials as for the 1st Margin firing for that purpose.

First, however, isolate the die again using IPS Ceramic Separating Liquid. Subsequently, supplement the missing areas by carefully inserting the shoulder material into the gap created during the 1st Margin firing so that the ceramic shoulder is provided with optimum fitting accuracy. Complete the shoulder, dry, and carefully remove the framework with the completed and dried shoulder material from the die and place it on the firing tray.



Firing parameters for the 1st and 2nd Margin firing see page 69

1st Dentin and Incisal firing

Isolate the model before layering the Dentin and Incisal materials. In this way, the ceramic material is prevented from drying out or sticking to the model respectively. Isolate the stone die and the adjacent areas using IPS Model Sealer. Additionally, separate the area of the pontics with IPS Ceramic Separating Liquid.



To achieve an optimum bond between the ceramic material and the opaquer surface, apply a small amount of IPS InLine Deep Dentin or Dentin material to the cervical and interdental areas (for bridges) and slightly roughen it. In this way, the adaption of the ceramic material on the opaquer surface is enhanced.

Make sure that the restoration is slightly overcontoured so that the actual tooth shape is achieved after firing. The bridge is lifted off the model to supplement the contact points with Dentin and Incisal materials. Before firing, separate the entire interdental area down to the opaquer.



Densify the ceramic surface (after contouring) with a large, dry brush toward the cervical margin before firing.



The ceramic material is applied according to the layering diagram.



For an optimum firing result, the interdental areas must be separated down to the opaquer.



Fired restoration after the 1st Dentin and Incisal firing



- Use distilled water to rewet the mixed or even already applied layering material.
- The firing tray with the opaqued metal framework should only be placed in the firing chamber and removed from it once the furnace head is completely open and the beeper has sounded.



Firing parameters 1st Dentin and Incisal firing see page 69.

2nd Dentin and Incisal firing

Finish and thoroughly clean the restoration. Clean under running water or with the steam jet. Blasting the restoration with Al_2O_3 (50 μm) at 1 bar (15 psi) pressure is only necessary if there is superficial contamination after cleaning. Thoroughly dry the restoration and complete the missing areas. Pay special attention to interdental spaces as well as contact points. Place the completely layered restoration on the firing tray and ensure adequate support. The firing tray with the restoration should only be placed in the firing chamber once the furnace head is completely open and the beeper has sounded. Use the firing parameters stipulated below to fire the restoration.



Supplementing the restoration with Dentin and Incisal materials



Final design of the occlusal surface



- Use distilled water to rewet the mixed or even already applied layering material.
- The firing tray with the opaqued metal framework should only be placed in the firing chamber and removed from it once the furnace head is completely open and the beeper has sounded.



Firing parameters 2nd Dentin and Incisal firing see page 69.

Margin Add-On firing

Margin Add-On is an add-on material for the ceramic shoulder area, which is applied after the main or add-on firing cycles with Dentin and Incisal materials. Thus, it is possible to adjust the accuracy of the marginal shoulder. Subsequently, the restoration is completed with the IPS Ivocolor Essence/Shade and Glaze materials that can be fired at lower temperatures.



Firing parameters for the Margin Add-On firing see page 69.

Add-On firing

Before the completion of a restoration, small adjustments, such as contact points, pontic rests, or fitting accuracy of the shoulder, may be necessary.

In order to employ a lower firing temperature, IPS InLine Dentin/Incisal materials can be mixed with IPS InLine Add-On in a 1:1 ratio and subsequently applied.



Firing parameters for the Add-On firing see page 69.

Individual finishing

Preparing for Stain and Glaze firing

Before the Stain and Glaze firing, the restoration has to be prepared as follows:

- Finish the restoration using diamonds and give it a true-to-nature shape and surface structure, such as growth lines and convex/concave areas.
- Areas which should exhibit a higher gloss after Glaze firing (e.g. pontic rests) can be smoothed out using silicone discs.
- If gold and/or silver dust was used to design the surface texture, the restoration has to be thoroughly cleaned with steam. Make sure to remove all gold or silver dust in order to avoid any discolouration after firing.



The true-to-nature shape and surface texture are designed.



Before the application of the glaze paste, the IPS InLine ceramic surface must not be too shiny. A too shiny ceramic surface favours the running off of the glazing paste into the crevices of the ceramic surface (e.g. interdental spaces). Slight blasting of the ceramic surface, e.g. with 50 µm aluminium oxide, promotes the wetting of the ceramic surface with glazing paste.



The further procedure for the Stain and Characterization firing as well as the Glaze firing are described in the chapter on completing the restoration (see page 62–66).



Individually designed and characterized bridge made of IPS InLine

IPS InLine® PoM – Accurate Press-On Technique

Framework design criteria

The framework design is key to the success of durable metal-ceramic restorations. The more attention given to the framework design, the better the final results and the clinical success will turn out to be.

Functional support of the veneering ceramic

The framework reflects the shape of the tooth in a reduced form. It should be designed in such a way that it supports the cusps and incisal edges resulting in a virtually even layer thickness of the veneering ceramic in the cusp-fissure area. In this way, the masticatory forces occurring during functional chewing are exerted on the framework rather than on the veneering ceramic. Therefore, the framework must not show any angles and edges (see diagram) so that the masticatory forces do not result in tension peaks, which may cause delamination and cracks. Any sharp angles or edges should be removed in the wax-up rather than grinding the metal framework. The wall thickness of the metal framework for single crowns must not be less than 0.3 mm and for bridge abutments 0.5 mm after finishing (see diagram). For further information, please refer to the Instructions for Use of the corresponding alloy.

Anterior crowns

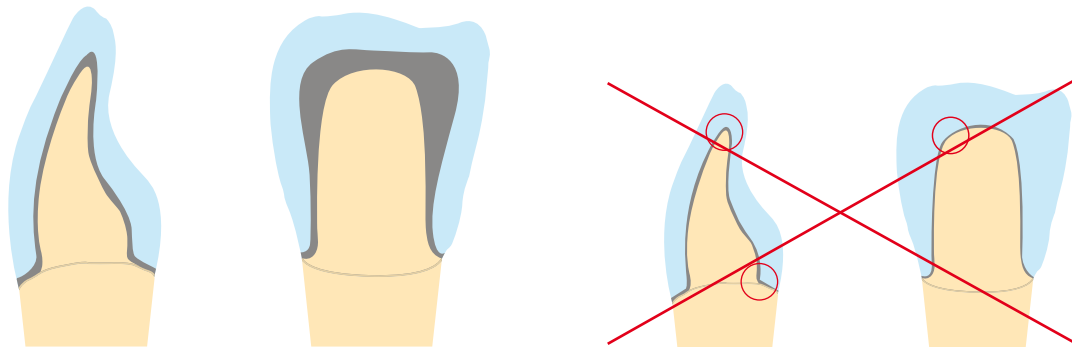

Premolar crowns

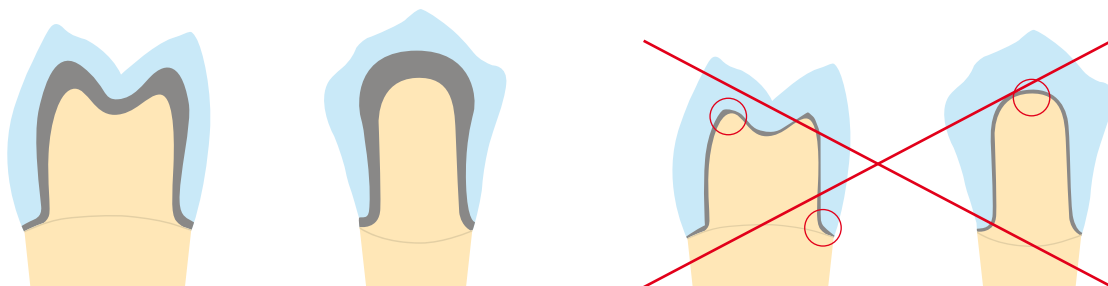

Molar crowns

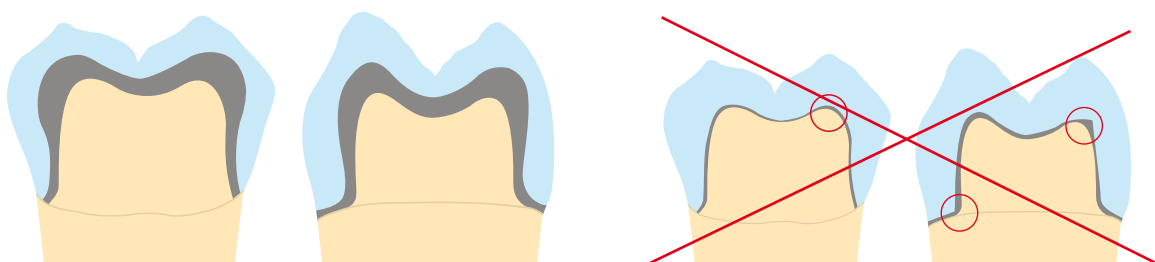

Framework design for pressed-on ceramic shoulders

With pressed on ceramic shoulders, make sure that the framework rather than the veneer is supported by the prepared tooth. The framework is thus reduced exactly to the inner edge of the chamfer or shoulder preparation. In this way, functional support of the framework on the preparation is achieved. Excellent fitting accuracy on the preparation is essential to ensure that the shoulder material may not reach the inner aspects of the framework during subsequent application.

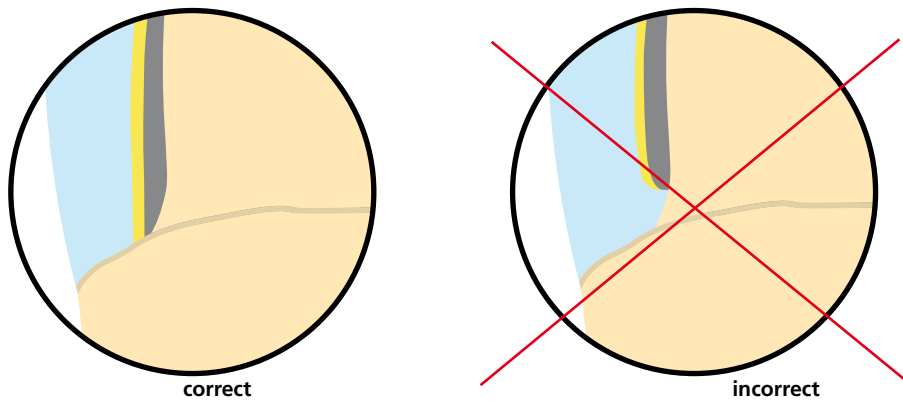

Framework stability

The dimensions and shape of the interdental connector surfaces decisively influence the stability of the restoration during processing, as well as the clinical long-term success after incorporation. Therefore, the dimensions of the interdental connector surface must be designed in accordance with the alloy used (take the 0.2% proof stress into account)! The thermal behaviour of the selected alloy during processing has to be considered when designing the framework.



Framework design for bridges

Thermal stress during firing and masticatory forces after cementation affect metal frameworks. Therefore, these forces must be transferred to the framework rather than the veneer. Particularly in the connector areas between bridge abutments and bridge pontics in bridge reconstructions, the stability must be ensured with the help of the framework design and adequate framework material thickness. The framework design and framework thickness must therefore meet all the optical and functional requirements, as well as the aspects of periodontal hygiene. A full wax-up with the corresponding reduction of the ceramic provides the best prerequisites.

During veneering with ceramic materials, the bridge framework is exposed to high temperatures several times. With an inappropriate framework design or insufficient framework thickness, the high temperatures during firing may result in distortion or inaccuracy of fit of the framework. A collar design with e.g. interproximal reinforcements, counteracts this development. Additionally, this framework design (e.g. with cooling grooves) ensures more even cooling of the restoration during the cooling phase. This is particularly important if high gold alloys are used.

In order to enable optimum oral hygiene with bridge restorations, the design of the interdental spaces should be given special attention. Adequate opening of the interdental area without creating black triangles should be considered when designing the framework in order to ensure proper periodontal hygiene with interdental brushes and dental floss.

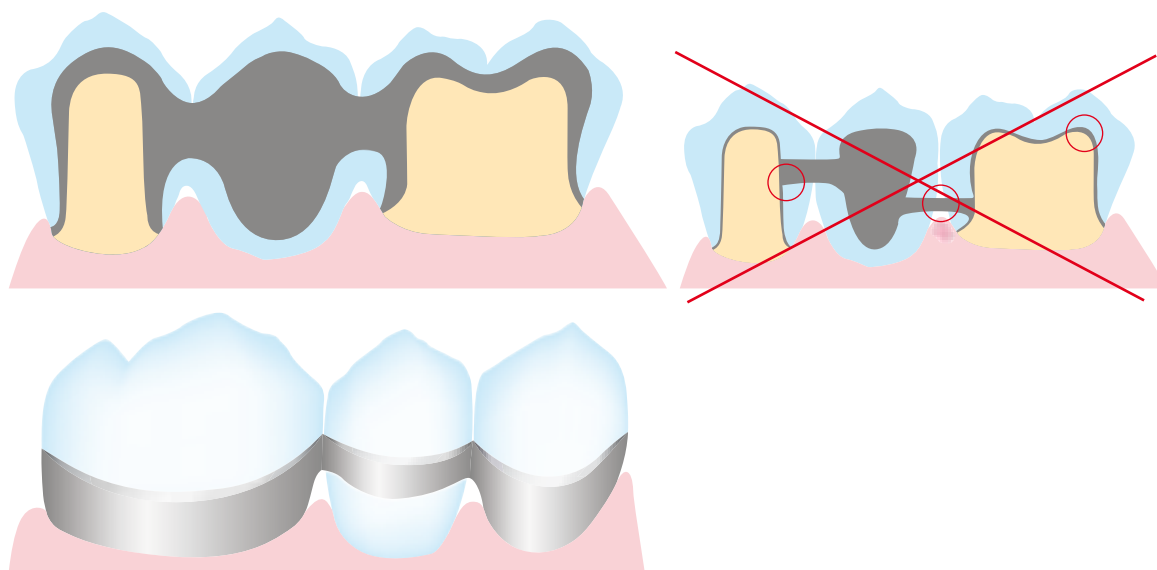

Design of bridge pontics

Bridge pontics are designed taking esthetic and functional aspects into account, as well as oral hygiene. The area of the pontic that contacts the alveolar ridge should be made of ceramic.

In order to ensure adequate stability between the bridge pontic and the bridge abutments, a palatal and/or lingual collar is recommended. Furthermore, to ensure even cooling of the bridge pontic that absorbs the most heat, additional cooling grooves are advantageous.

**Bridge pontic design –
ovate pontic**



**Bridge pontic design –
saddle-type pontic**

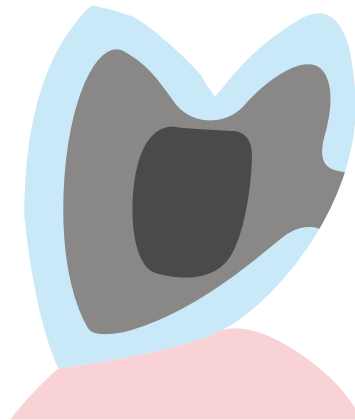

Interface between metal and ceramic

The interface between the metal framework and the veneering ceramic must be clearly defined. If possible, incorporate a right angle finish line. The junctures between the metal framework and the veneering ceramic must not be located in the contact area nor on surfaces involved in masticatory functions. The interface in the interdental area should be designed in such a way that cleaning of these difficult-to-access areas is possible.

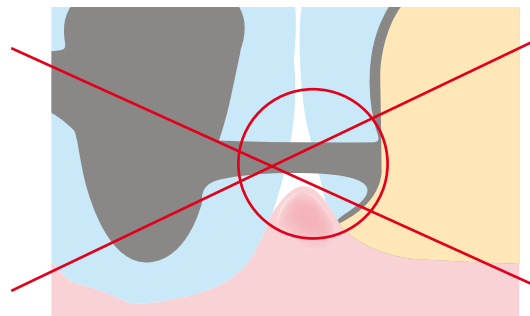
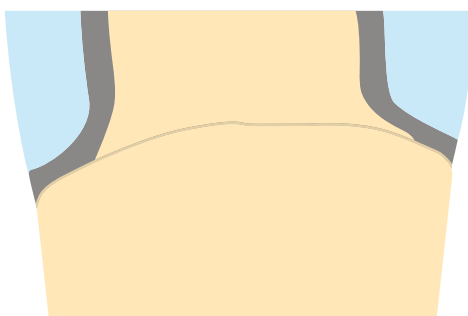
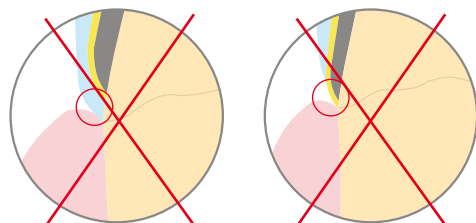
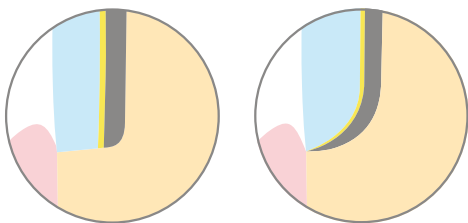

Retention pins

It is important for the press-on-metal technique that retention pins are attached to the crown and bridge frameworks. These retention pins have to be attached in the area of the pontics or the collars. They are directly attached to the framework with the help of wax. Dimensions of Ø 1.0–1.5 mm for the retention pins have proven to be useful.

Advantages of cast-on retention pins:

1. Act as cooling grooves during casting and firing
2. Retention for improved fixation in the investment material during the press-on procedure with IPS InLine PoM
3. Handling aid for further processing

The retention pins have to be shaped in such a way that the bridge framework cannot distort and/or move in the investment material. At least 2 retention pins (diverging) have to be provided for bridge frameworks, one of which has to be positioned in the area of the pontic.

If straight wax wires are used, 2 diverging wires have to be applied for bridges. A profile has to be positioned in the area of the pontic.

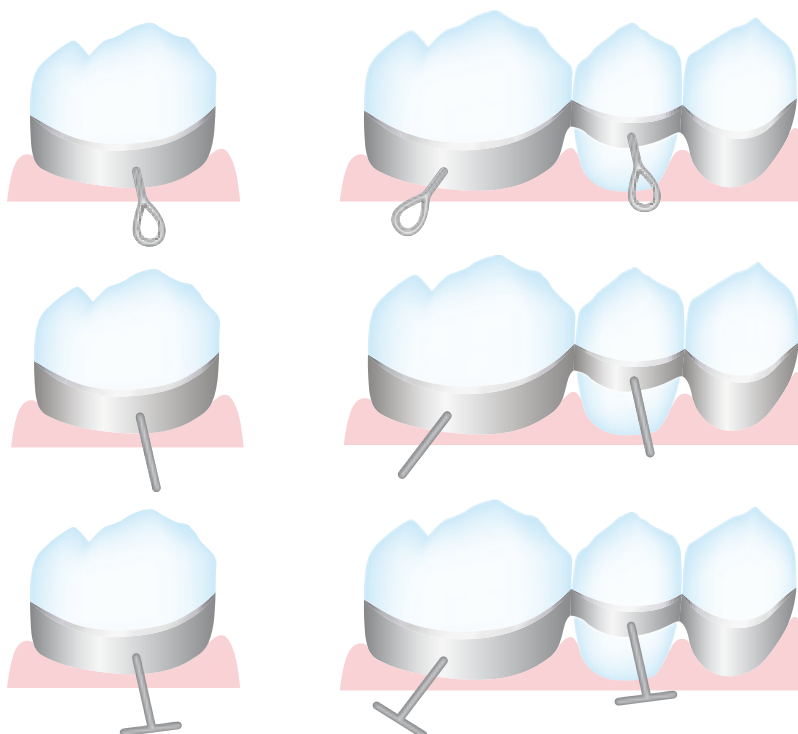

The retention pins must be placed in such a way that they do not interfere during try-in or in the articulator. They should only be removed without causing overheating once the restoration has been completed.



Please refer to the "Framework Design Manual for Metal-Ceramic Restorations" for additional information on framework design. They can be ordered from your Ivoclar Vivadent contact address.

Step-by-step procedure

Starting situation



Maxillary and mandibular model articulated in the "Stratos 200"



Starting situation for the metal-supported IPS InLine PoM restoration

Framework design

Design the framework with a reduced anatomical shape taking the planned press-on procedure into account. The wall thickness of single crowns should be at least 0.3 mm and at least 0.5 mm for abutment crowns. Make sure to provide sufficient stability of shape for the framework. Avoid sharp transitions and edges. Design the connector areas between the individual units in such a stable way that they meet the requirements for interdental hygiene and the alloy used.

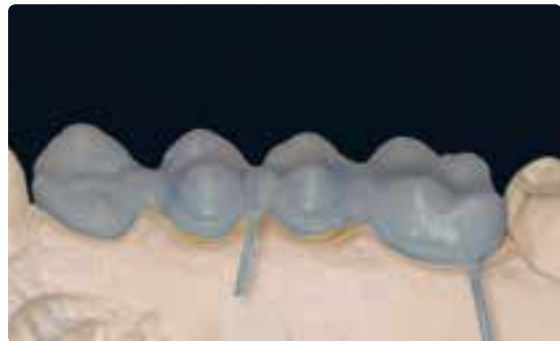
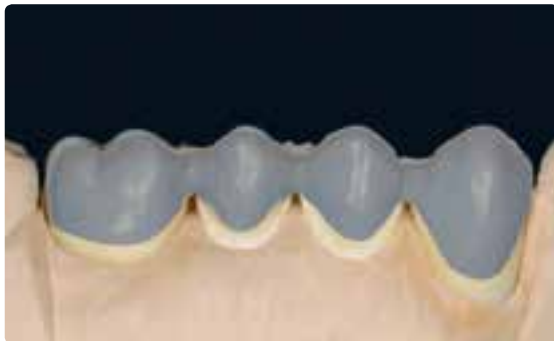

Design the framework in a reduced supported shape.

- Due to the optical properties, the ceramic should feature a thickness of at least 0.8 mm in connection with the press-on-metal technique.
- Especially if frameworks are to be pressed over, it is recommended to attach retention grooves in the palatal / lingual area.

Alloy processing / oxide firing

The cast metal framework is finished using tungsten carbide metal burs or ceramic-bonded grinding instruments. To make room for the ceramic shoulder (labial or circular), the marginal area of the framework is reduced up to the inner edge of the chamfer or shoulder preparation.



Surface finishing before blasting.



Carefully blast the framework with aluminium oxide Al_2O_3 50–100 μm (observe the instructions of the alloy manufacturer).



After blasting, clean the metal framework with a steam jet and allow to dry thoroughly. Conduct the oxide firing according to the instructions of the manufacturer.

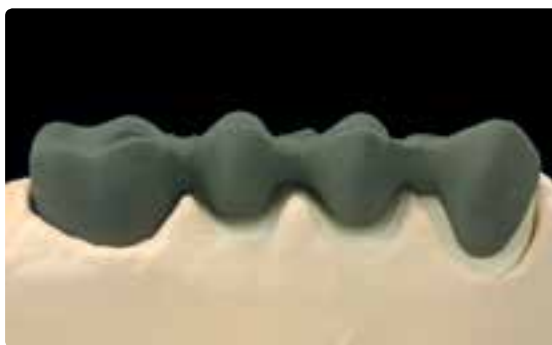

After oxide firing, the framework should exhibit an evenly oxidized surface.

Layering diagram IPS InLine® PoM

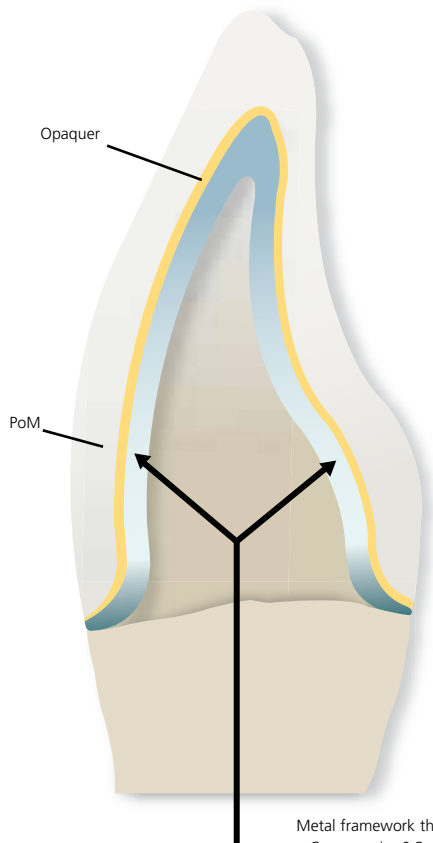

Metal framework thickness:
 – Crowns min. 0.3 mm
 – Bridge abutments min. 0.5 mm

	Ideal layer thickness	Limited layer thickness
Framework	0.3–0.5 mm	0.3–0.5 mm
Opaquer	0.1 mm	0.1 mm
PoM	0.8–1.5 mm	0.8

These figures are drawn from past experience and they may vary in certain situations.

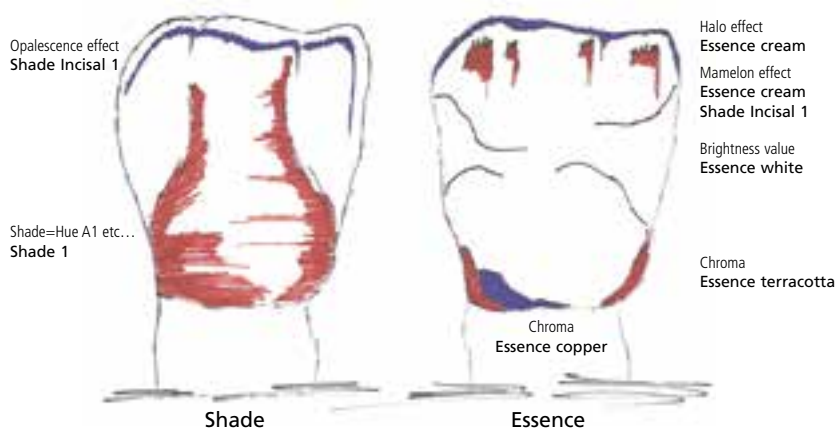

Depending on the desired individualization, IPS Ivocolor Essence / Shades can be used to achieve true-to-nature shade effects.

Opaquer firing

Paste opaquer

1st Opaquer firing (wash firing), (paste opaquer)

Select the IPS InLine System Opaquer paste in the corresponding tooth shade. If required, homogenize the opaquer paste by agitating it before taking it from its container. Extrude the desired amount from the syringe or jar and mix thoroughly on the mixing pad. Thin it, if required. Apply the first opaquer layer thinly and agitate it into the alloy surface. After firing and cooling, clean the opaquer metal framework with the steam jet and subsequently dry with oil-free air.



The consistency of the paste opaquer can be individually adjusted using the IPS InLine System Opaquer Liquid.

2nd Opaquer firing (paste opaquer)

Apply the 2nd opaquer layer in an even, covering layer. After firing, the IPS InLine System Opaquer should show a covering, silky-mat shiny surface. After the opaquer firing, the conditioned surfaces of the alloy should be entirely covered with opaquer.



The firing tray with the opaquer metal framework should only be placed in the firing chamber and removed from it once the furnace head is completely open and the beeper has sounded.



Firing parameters for the 1st and 2nd Opaquer firing see page 70.

IPS InLine® System Opaquer F

The Opaquer F can be used to reinforce the in-depth fluorescence.

- **Either:** Apply the Opaquer F as a thin, **third** opaquer layer and fire (930 °C/1706 °F).
- **or:** Mix up to 20% of Opaquer F with the conventional IPS InLine System Opaquer before the second layer is applied and fire at 930 °C/1706 °F.



Wax-up

After the fabrication of the model with detachable segments and the preparation of the dies, the restoration is contoured. Use only organic waxes for contouring, since they fire without leaving residue.

- Weigh the metal framework coated with opaquer and record the weight. The weight is used to determine the wax weight after contouring.
- Subsequently, secure the framework on the model in the proper position and wax the margins first.
- Fabricate a fully anatomical wax-up as usual. Observe a layer thickness of at least 0.8 mm. Make sure not to exceed a thickness of 1.5 mm in order to ensure optimum shade reproduction.
- Observe a wax thickness of at least 0.8 mm to avoid incomplete press results.



Fully anatomical wax-up on the metal framework. Observe the minimum layer thicknesses at all times.

Sprueing

The diameter for the sprues is 3 mm. For multi-unit bridges, each bridge unit must be provided with a sprue. Always attach the sprues in the direction of flow of the ceramic and at the thickest part of the wax-up so that smooth flowing of the viscous ceramic during pressing is enabled. Depending on the number of objects to be invested, either the 100 g, 200 g, or 300 g IPS Investment Ring System is selected. Bridges must only be pressed in the 200 g or 300 g IPS Investment Ring System.

The following sprueing guidelines have to be observed:

	Single crowns, bridges
Investment ring base	100 g, 200 g, 300 g
Wax wire Ø	3 mm
Length of the wax wire	min. 3 mm, max. 10 mm
Length of the wax wire including waxed-up object	max. 15–16 mm
Sprue attachment point at the waxed-up object	thickest part of the wax-up; every bridge unit
Sprue angle to the waxed-up object	in the direction of flow of the ceramic; observe the cusp angulation
Sprue angle to the ring base	45-60°
Design of the attachment points	rounded, no angles or edges
Distance between the objects	min. 3 mm
Distance to the silicone ring	crowns: min. 10 mm; bridges: 5–8 mm
Important	Larger bridges may also be placed in the centre of the investment ring.



On the IPS Investment Ring Base, always attach sprues in the direction of flow of the ceramic and to the thickest part of the restoration.

Correct sprueing

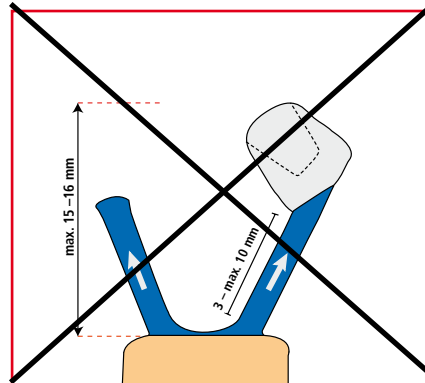
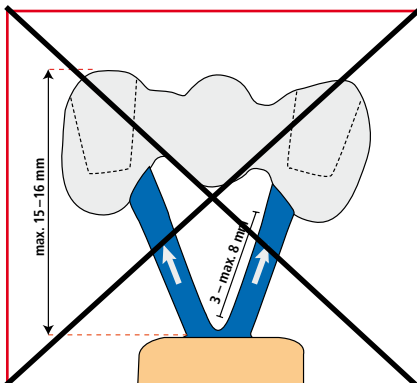
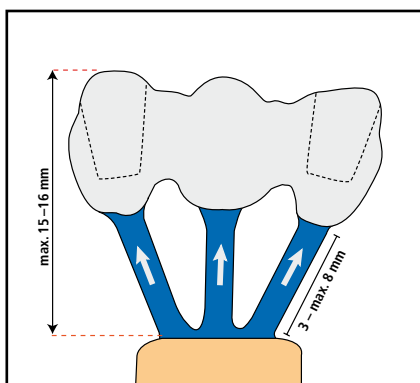

Direct the sprues towards the wax pattern (imagine continuation of wax pattern).

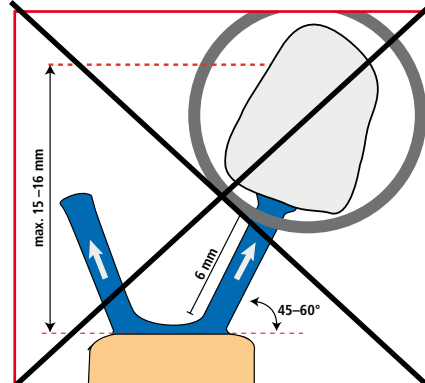
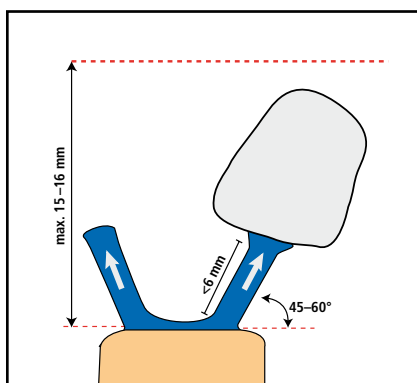
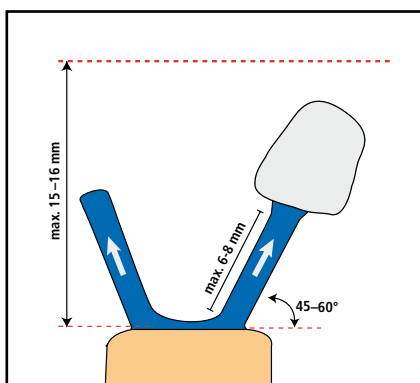

The sprue and object together should be no longer than 15-16 mm. Observe a 45-60° angle.

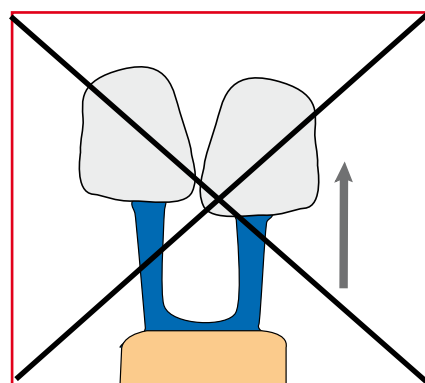
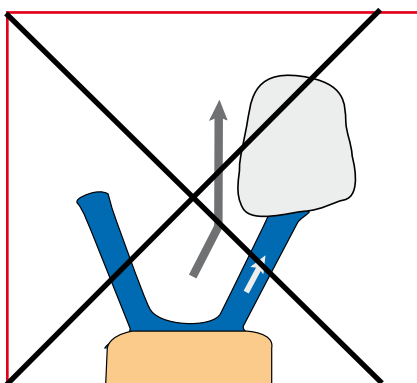
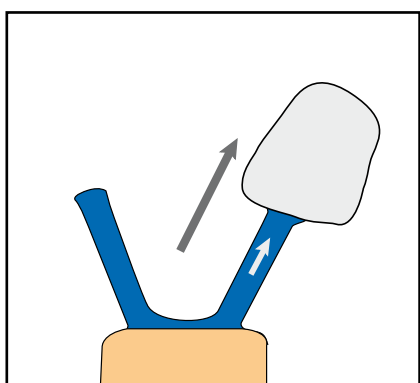

Provide sprues in the direction of flow of the ceramic material.

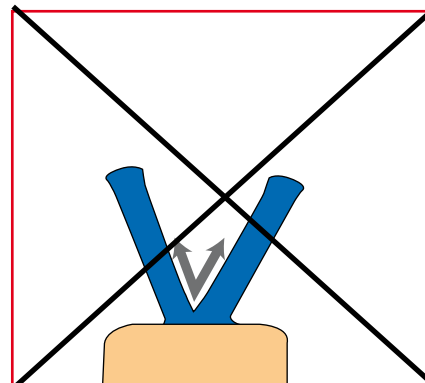
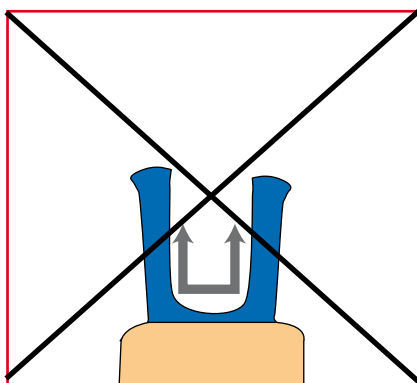
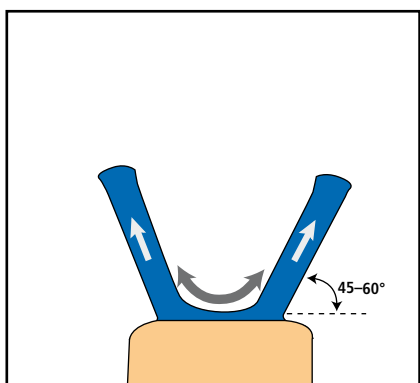

The attachment points of the sprues must be rounded. Observe a 45-60° angle.

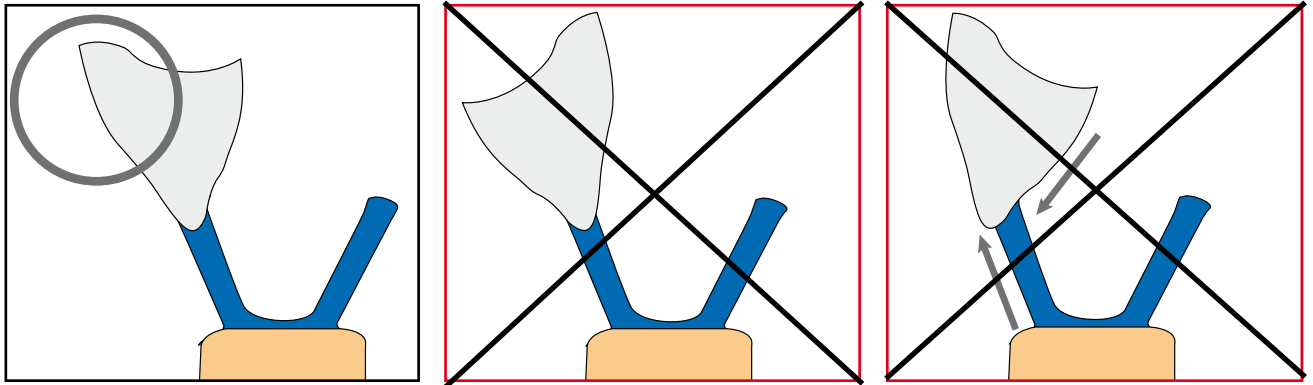

If the crown is viewed from the proximal, the longer side of the object (usually the buccal surface) points outwards. Additionally, the flow of the ceramic material must be observed.

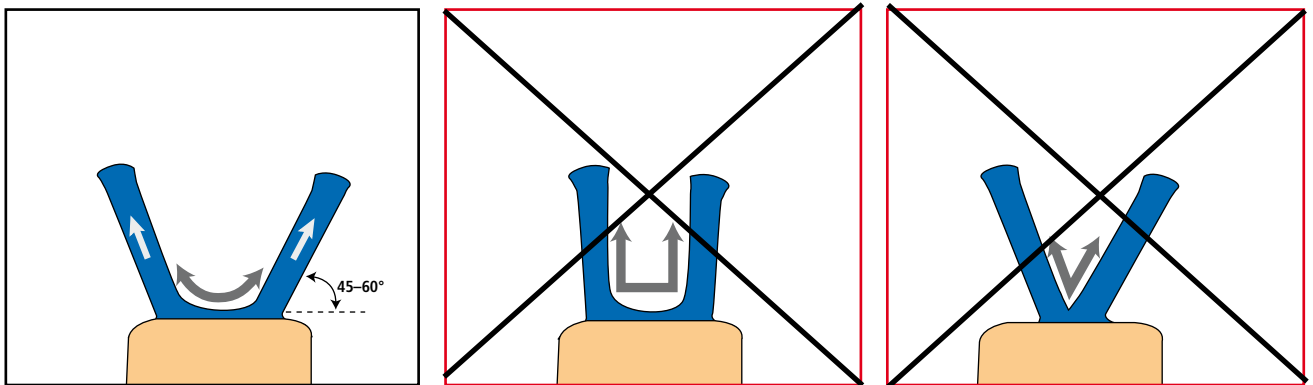

The attachment points of the sprues must be rounded. Observe a 45-60° angle.

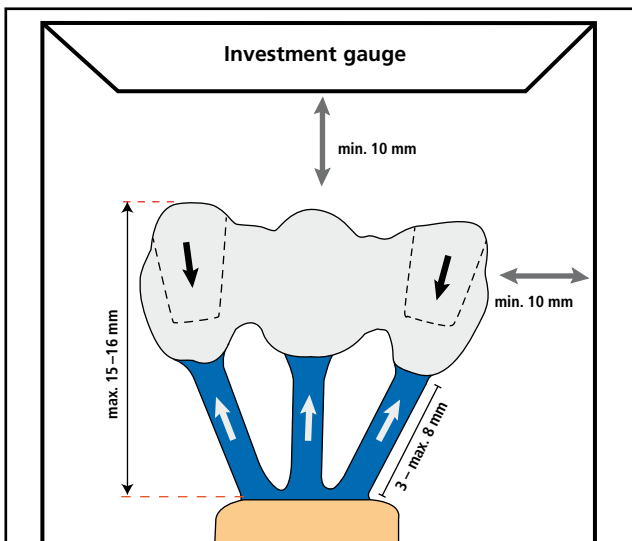

Investing

Investment is carried out with IPS PressVEST Premium (conventional or speed procedure). For that purpose, the IPS Silicone Ring with the matching investment ring gauge is used. Determine the precise wax weight as follows:

- Weigh the ring base (seal the opening of the ring base with wax).
- Position the objects to be pressed on the ring base and attach them with wax. Weigh again.
- The wax weight is calculated by deducting the weight of the ring base and the weight of the framework (including opaquer) from the total weight.

	100 g	200 g		300 g	
Number of ingots S	1x	1x	2x	3x	6 x
Max. wax weight	0.6	0.6	2.0	2.1	5.1



Please refer to the Instructions for Use of the IPS Press Vest Premium investment material for the detailed processing parameters.

The following procedure is recommended:

- Do **not** use a debubbler on the wax objects. Remove separator thoroughly with oil-free compressed air.
- Mix the investment material. The investment material contains quartz powder. Therefore, avoid the inhalation of dust.
- Use a suitable instrument for the fine investment of the cavity. Make sure that the delicate wax margins are not damaged.
- Carefully place the IPS Silicone Ring on the ring base without damaging the wax objects. The silicone ring must sit flush on the investment ring base.
- Subsequently, carefully fill the investment ring with investment material up to the marking and position the ring gauge with a hinged movement.
- Allow the investment ring to set without manipulating it.
- Do not use IPS PressVEST Premium for investment over the weekend to prevent crystallization.

Investment material mixing ration

Investment material	100 g Investment Ring	200 g Investment Ring	300 g Investment Ring
IPS PressVEST Premium	18 ml liquid 8 ml dist. water	36 ml liquid 16 ml dist. water	54 ml liquid 24 ml dist. water



Preheating

After the stipulated setting time of the investment material IPS PressVEST Premium, the investment ring is prepared for preheating as follows:

- Remove the ring gauge and ring base with a turning movement.
- Carefully push the investment ring out of the IPS Silicone Ring.
- Remove rough spots on the bottom surface of the investment ring with a plaster knife. Check the 90° angle. Investment material residue must not enter the sprues. Blow into the sprues if necessary.
- If several investment rings are preheated together, mark them with the respective ingot shade.
- When placing several investment rings in the preheating furnace using the Speed method, make sure that the furnace temperature does not drop too much.

	IPS PressVEST Premium	
	Conventional preheating	Speed procedure
Setting time	min. 30 min, max. 12 hrs	min. 30 min, max. 45 min
Temperature of the preheating furnace when placing the investment ring	Room temperature	850°C / 1562°F; switch on the preheating furnace in time.
Position of the investment ring in the preheating furnace	with the opening facing down	with the opening facing down
Temperature increase	3°C/min	–
Holding temperature / time	280°C/45 min	–
Final temperature for preheating the investment ring	850°C	850°C
Holding time of the investment ring at final temperature	100 g investment ring: min. 45 min. 200 g investment ring: min. 60 min. 300 g investment ring: min. 90 min.	100 g investment ring: min. 45 min. 200 g investment ring: min. 60 min. 300 g investment ring: min. 90 min.
IPS InLine PoM ingot	no preheating	
IPS AloX plunger		
Important	When using the conventional preheating procedure always place investment rings in the cold preheating furnace and start heating from room temperature. Make sure that the investment rings do not dry out until the start of the preheating program.	If several Speed investments are to be conducted (e.g. 2 x 200 g investment rings), they should be invested consecutively and placed into the preheating furnace at an interval of approx. 20 minutes. When placing the investment rings in the preheating furnace, make sure that the furnace temperature does not drop substantially. The stipulated holding time counts from the point when the preheating temperature has been reached again.









Do **not** preheat the IPS InLine PoM ingots and the IPS One-Way plunger/AloX plunger.

In order to ensure smooth working procedures in the laboratory on a daily basis, impeccable functioning of the infrastructure, particularly the preheating furnaces, is essential. This includes their maintenance, cleaning with a vacuum cleaner in a cool state as well as regular checks of the temperature controls and heating elements, etc., by the manufacturer.

Ingot selection

Select the proper ingot. Only seven shades are sufficient to reproduce all the Chromascop, A–D and Bleach shades. Therefore, it is possible to press fully anatomical restorations for different patient cases in one press cycle. The final tooth shade is achieved by individual characterization using the IPS Ivocolor Essence/Shade and Glaze materials.

	BL	1	2	3	4	5	6
5 ingots							
Ingot & Touch Up	BL1, BL2, BL3, BL4	A1, B1	A2, B2, C1, D2	A3, A3.5	B3, B4	C2, D3, D4	A4, C3, C4
	110, 120, 130, 140	210, 220, 230, 240	–	310, 320, 330, 340	410, 420, 430, 440	510, 520, 530, 540	

Pressing with the 100 g, 200 g, 300 g IPS Investment Ring System

IPS Alox plunger for the IPS Investment Ring System 100 g, 200 g,

Before pressing, the press furnace must be switched on early and preheated to the stand-by temperature.



Provide a **cold** IPS Alox plunger and **cold** IPS InLine PoM ingots in the desired shade.



Insert the **cold** IPS InLine PoM ingot with the imprint facing upwards into the **hot** investment ring.



Then, place the powder-coated IPS Alox plunger into the **hot** investment ring.

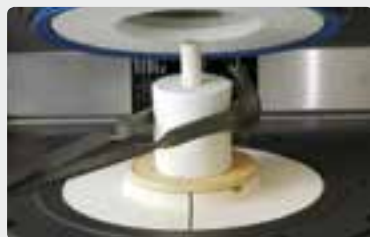

Place the **hot** and completed investment ring in the centre of the **hot** press furnace using the IPS Investment Ring Tongs



Press **START** to start the selected program.



Once the press program is completed, place the hot investment ring on the cooling grid using the investment ring tongs and allow it to cool to room temperature.



Press with the "IPS inLine PoM" program stored in the Ivoclar Vivadent press furnace for the correct investment ring size (e.g. 200 g).

IPS One-Way Plunger 300 g for IPS Investment Ring System 300 g



Provide a **cold** IPS One-Way plunger and **cold** IPS InLine PoM ingots in the desired shade.

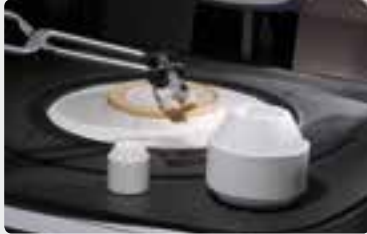

Insert the **cold** IPS InLine PoM ingots with the imprint facing upwards into the **hot** investment ring.



Place the **cold** IPS One-Way plunger 300 g in the **hot** investment ring.



Place the **hot** and completed investment ring in the centre of the **hot** press furnace using the IPS Investment Ring Tongs.



Press **START** to start the selected program.



Once the press program is completed, place the hot investment ring on the cooling grid using the investment ring tongs and allow it to cool to room temperature.



Press with the "IPS inLine PoM" program stored in the Ivoclar Vivadent press furnace for the correct investment ring size (e.g. 300 g).

Divesting

Once the investment ring has cooled to room temperature (approx. 60 min.), divest as follows:

- Mark the length of the Alox plunger (100 g and 200 g investment ring) or the One-Way plunger (300 g investment ring) on the cooled investment ring.
- Separate the investment ring using a separating disc. The predetermined breaking point enables reliable separation of the investment material and the ceramic material.
- Always use polishing beads to divest the pressed objects (rough and fine divestment). Do not use Al_2O_3 .
- Rough divestment is carried out with polishing beads at 4 bar (58 psi) pressure.
- Fine divestment is carried out with polishing beads at 1–1.5 bar (29 psi) pressure.
- Observe the blasting direction and distance to prevent damage to the object margins during divestment. Cover the marginal areas with a finger.



Mark the length of the Alox plunger.



Separate the investment ring using a separating disc.



The Alox plunger is already very clean if it is removed with tongs from the investment material. Check the cleanness and blast with Al_2O_3 , if required.

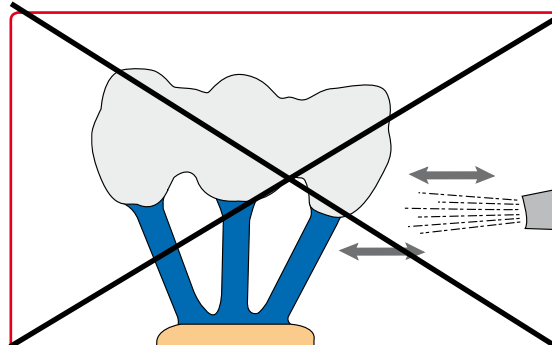
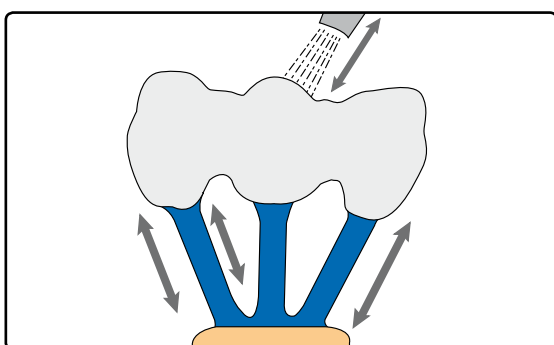

Sandblasting the objects

Separating / finishing

After separation of the sprues and smoothing of the attachment points, the pressed object is fitted to the master model. For that purpose, the usual rotary instruments (as those used for IPS e.max®) are used (without pressure and over-heating). After that, carefully sandblast the restoration. Finally, clean the restoration under running water or with steam. Dry thoroughly with oil-free air.



Bridge with sprues

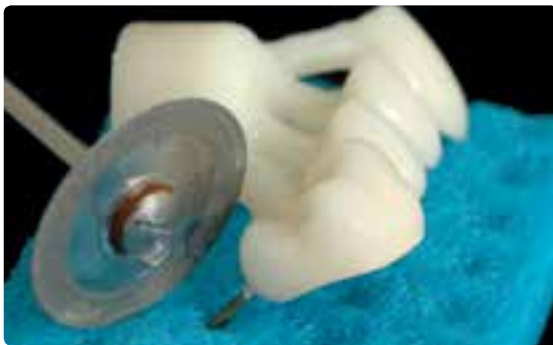

Special attention is required for separating the palatal metal retention pin. Make sure to separate and polish the retention pin carefully after glazing without creating too much heat.

Adjustments with IPS InLine® PoM Touch Up

For minor shape adjustments, such as incompletely pressed margins or occlusal surfaces, the 7 Touch Up materials are available in the respective ingot shade. The Touch Up materials must only be used for metal-supported IPS InLine PoM restorations.

Processing

- The restoration must be free of dirt and grease prior to adjustment. For that purpose, thoroughly clean the restoration using the steam jet.
- Apply the IPS InLine PoM Touch-Up material mixed with IPS InLine System Build-Up Liquid on the missing, cleaned areas using a brush and slightly blot with an absorbent cloth.
- Place the restoration on the firing tray and fire it.
- Next, finish the restoration or apply second Touch-Up adjustments and fire with the same parameters.



Adjustments with IPS InLine PoM Touch Up



Firing parameters for the IPS InLine PoM Touch Up firing see page 70.

Individual finishing

Preparing for Stain and Glaze firing

Before the Stain and Glaze firing, the restoration has to be prepared as follows:

- Finish the restoration using diamonds and give it a true-to-nature shape and surface structure, such as growth lines and convex/concave areas.
- Areas which should exhibit a higher gloss after Glaze firing (e.g. pontic rests) can be smoothed out using silicone discs.
- If gold and/or silver dust was used to design the surface texture, the restoration has to be thoroughly cleaned with steam. Make sure to remove all gold or silver dust in order to avoid any discolouration after firing.



The true-to-nature shape and surface texture are designed.



Before the application of the glaze paste, the IPS InLine ceramic surface must not be too shiny. A too shiny ceramic surface favours the running off of the glazing paste into the crevices of the ceramic surface (e.g. interdental spaces). Slight blasting of the ceramic surface, e.g. with 50 µm aluminium oxide, promotes the wetting of the ceramic surface with glazing paste.



The further procedure for the Stain and Characterization firing as well as the Glaze firing are described in the chapter on completing the restoration (see page 62–66).



Individually designed and characterized bridge made of IPS InLine PoM

IPS InLine® – Veneers

The following chapter shows the step-by-step layering of veneers on refractory dies.

Important: After each working step, the master model has to be immersed in water for about 5–10 minutes, depending on the size.



For the veneer fabrication, smaller working steps and several intermediate firing cycles are recommended.

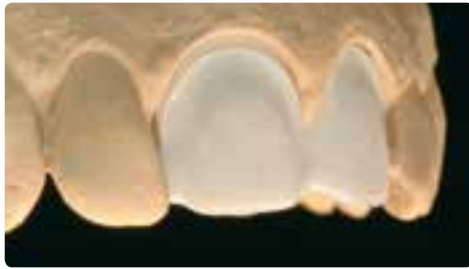

Model fabrication

Fabricate a duplicate model using a commercially available refractory die material, e.g. BegoForm® from Bego, Cosmotech VEST from GC or G-CERA™ VEST from GC (observe the instructions of the manufacturer).

Important: Correct processing and properly degassed dies are an important prerequisite for accurately fitting veneers.



Wash firing

After degassing the refractory dies, apply IPS InLine Add-On mixed with the IPS Ivocolor Mixing Liquid allround in a thin layer and fire.



Firing parameters for the **Wash firing** see page 71.



Cervical firing

Build up the marginal areas using a mixture of IPS InLine Dentin and, for example, Occlusal Dentin brown.



Firing parameters for the **Cervical firing** see page 71.



Dentin/Impulse firing

Internal layering is modelled on the natural characteristics and consists of a dentin build-up and various effects. Individual layering with the Impulse materials enables mamelons, opalescence and translucent effects to be achieved.



Firing parameters for the **Dentin/Impulse firing** see page 71.



Incisal firing

Subsequently, build up the outer enamel layer and fire.



Firing parameters for the **Incisal firing** see page 71.



Glaze firing

Apply the IPS Ivocolor Glaze on the surface and fire.



Firing parameters for the **Glaze firing** see page 71.



The further procedure for the Stain and Characterization firing as well as the Glaze firing are described in the chapter on completing the restoration (see page 62–66).



Divesting the veneers

Remove large amounts of die material using a grinding disc. Fine divestment is carried out with polishing beads at max. 1 bar (30 psi) pressure.



Conditioning the veneers for adhesive cementation

Etch the inner aspect of the veneer with IPS Ceramic etching gel for 120 seconds in preparation for adhesive cementation. Next, thoroughly rinse the object with running water and dry.

Important: IPS InLine veneers must be placed with the adhesive technique.

IPS InLine® – Completion

IPS Ivocolor

IPS Ivocolor is the **universal stains and glaze assortment** for the **individualized staining** and **characterization** of ceramic materials. The range of products has been coordinated with the layering, press and CAD ceramics as well as the zirconium oxides from Ivoclar Vivadent and enables application irrespective of the CTE of the ceramic. Owing to the optimized sinter temperature of the newly developed glass, optimum esthetic results can be achieved irrespective of the ceramic substrate.

The newly developed composition of the pastes were optimized with regard to the application behaviour and firing results. The gel-type structure of the pastes can be optimally adjusted to the desired consistency for the application by way of the degree of dilution. It thus provides individual possibilities with regard to the surface texture and the degree of gloss of the restoration.

From surface staining to the shading of layering materials – IPS Ivocolor offers a solution for any technique

Mixing ratios: IPS Ivocolor Essence powders are intensively shaded and must only be added in small amounts (max. 5%) to the respective carrier materials.



You can find detailed information about the application of IPS Ivocolor Glaze, Shades and Essences in the IPS Ivocolor Instructions for Use.



Stain and Characterization firing



IPS Ivocolor Shade

The IPS Ivocolor Shade pastes are used to stain the materials. They are preferably used for surface staining.

Thoroughly clean the restoration with the steam jet and dry with oil-free air.

Dispense the desired quantity of IPS Ivocolor Shade and slightly dilute it with the IPS Ivocolor Mixing Liquid allround or longlife to achieve the desired consistency.



Apply IPS Ivocolor Shade in the cervical and dentin area and verify the shade match with the help of the shade guide.

If only minor shade adjustments are required, they may be done during the Glaze firing. A Stain firing before the Glaze firing is recommended for major shade adjustments.



IPS Ivocolor Essence

The IPS Ivocolor Essence powders are used for individualized characterizations. This chapter describes the surface staining with IPS Ivocolor Essences. You can find detailed information about the application of IPS Ivoclar Essence powders in the IPS Ivocolor Instructions for Use.



Thoroughly clean the restoration with the steam jet and dry with oil-free air.

Dispense the desired quantity of Essence and mix it with the IPS Ivocolor Mixing Liquid allround / longlife or Essence Fluid, depending on the intended consistency.



After that, use IPS Ivocolor Essence to apply individualized characterizations to the ceramic surface, such as discolourations or ...



... white spots.



These stains can be set in place with a separate **Stain firing** (see firing parameters on page 68–71).

Minor shade adjustments and individual characterizations may also be fired together with the glaze material.



- Pooling should be avoided and the material must not be applied too thickly.
- More intensive shades are achieved by several staining procedures, not by applying thicker layers.
- If the desired shade is not achieved, an additional stain firing cycle is conducted using the same firing parameters.
- IPS Ivocolor Shade and IPS Ivocolor Essence can be mixed with each other. To adjust the consistency, use only the IPS Ivocolor Mixing Liquids allround / longlife.

Glaze firing with IPS Ivoclor

Glaze firing with glazing material

Thoroughly clean the restoration with the steam jet and dry with oil-free air.

Remove IPS Ivocolor Glaze Powder/FLUO or Glaze Paste/FLUO from its container and slightly dilute and mix it with the IPS Ivocolor Mixing Liquid allround or longlife.



Next, apply the Glaze material using a brush. Subsequently apply the minor shade adjustments, if required, using IPS Ivocolor Shade and/or Essence on the already apply glazing material and fire with the **Glaze firing**.



- The degree of gloss of the glazed surface is controlled via the consistency of the glazing material and the applied quantity, not by means of the firing temperature. For a higher degree of gloss, the glazing material has to be applied in a correspondingly thicker layer.
- Additional Glaze firing cycles can be conducted with the same firing parameters.
- The ceramic surface must not be too smooth to prevent the glazing paste from running off.



Firing parameters for the Glaze firing with IPS Ivocolor see pages 68–71.



IPS Ivocolor Essence Fluid is not suitable for dilution.

Add-On after Glaze firing

After the completion of a restoration, small adjustments, such as contact points, pontic rests, shoulder adjustments, may be necessary.

Mix the IPS InLine System Add-On 690°C/1274°F material with the desired build-up liquid, apply on the missing areas, and fire.



Firing parameters for the IPS InLine System Add-On 690°C/1274°F after Glaze firing see pages 68–71.



Special attention is required for separating the "retention pins". Make sure to separate and polish the retainer carefully after glazing without creating too much heat.

IPS InLine® One/IPS InLine®/IPS InLine® PoM

General Information

Cementation

Your dentist can place the metal-supported IPS InLine restorations as usual following a conventional cementation protocol. IPS InLine veneers must be placed with the adhesive technique.

The following materials are recommended for cementation:

	Self-adhesive composite cement	Glass ionomer cement	Universal luting composite	Esthetic luting composite
Material	SpeedCEM® Plus	Vivaglass® CEM	Multilink® Automix	Variolink® Esthetic
Curing	Self-curing with light-curing option	Self-curing	Self-curing with light-curing option	Light-curing
Cementation method	Self-adhesive	Conventional	Adhesive: Multilink® Primer A/B	Adhesive: Adhese® Universal or Syntac®
IPS InLine One One-layer metal-ceramic	✓	✓	✓	
IPS InLine Conventional metal-ceramic	✓	✓	✓	
IPS InLine PoM Press-on-Metal ceramic	✓	✓	✓	
IPS InLine Veneers				✓



Please observe the corresponding instructions for use

✓ Recommended product combinations

Conditioning of the metal-ceramic restoration

- Blast the inner aspects of the crown with Al₂O₃ until an even mat surface has been achieved.
- If necessary, clean the restoration in an ultrasonic unit for about 1 minute.
- Thoroughly rinse the restoration with water spray and dry with oil-free air.
- **Important:** In order to create a strong bond, do not clean the metal surfaces with phosphoric acid.
- Apply Monobond® Plus with a brush or a Microbrush to the pre-treated surfaces, let it react for 60 s and then disperse with a strong stream of oil-free air.

Condition of the veneers

Version 1 with Monobond Plus

- Thoroughly rinse the veneer with water spray and dry with water- and oil-free air.
- Etch the inner aspect of the veneer with IPS Ceramic Etching Gel for 120 seconds.
- Thoroughly rinse the veneer with water spray and dry with oil-free air.
- Apply Monobond Plus to the pre-treated surfaces with a brush or Microbrush, leave to react for 60 s and then disperse with a strong stream of air.



Version 2 with Monobond Etch & Prime

- Thoroughly rinse the veneer with water spray and dry with water- and oil-free air.
- Apply Monobond Etch & Prime on the adhesive surface using a Microbrush and agitate into the surface for 20 seconds. After that, allow to react for another 40 seconds.
- Then thoroughly rinse off Monobond Etch & Prime with water and dry the restoration with a strong jet of water- and oil-free air for approximately 10 seconds.



IPS InLine® One – One-layer metal-ceramic

Firing parameters

IPS InLine One One-layer metal-ceramic	Firing temperature T [°C/°F]	Stand-by temperature B [°C/°F]	Closing time S [min]	Heating rate t [°C/°F/min]	Holding time H [min]	Vacuum on V₁ [°C/°F]	Vacuum off V₂ [°C/°F]
1 st /2 nd Paste Opaquer firing	930/1706	403/757	6:00	100/180	2:00	450/842	929/1704
1 st Dentsisal firing	910/1670	403/757	4:00	60/108	1:00	450/842	909/1668
2 nd Dentsisal firing	900/1652	403/757	4:00	60/108	1:00	450/842	899/1650
Stain firing with IPS Ivocolor	830/1526	403/757	6:00	60/108	1:00	450/842	829/1524
Glaze firing with IPS Ivoclor	830/1526	403/757	6:00	60/108	1:00	450/842	829/1524
Add-On after Glaze firing (690 °C/1274 °F)	690/1274	403/757	4:00	60/108	1:00	450/842	689/1274



All the firing programs described in these Instructions for Use are run without active cooling. After the holding time, the furnace heater is switched off and furnace head cools down with a device-related cooling gradient with the help of the time-controlled opening of the furnace head. If long-term cooling is conducted, the closed furnace head cools down to 800°C /1472°F or 700°C/1292°F after the heater is switched off, at which point the time-controlled opening of the furnace head provides the device-related cooling gradient.

These firing parameters are guidance values. They are valid for the Programat® furnaces from Ivoclar Vivadent.

Deviations (approx. +/- 10 °C/18 °F) may occur:

- Depending on the furnace generation
- Ceramic furnaces from other manufacturers
- In case of regional differences in the power supply or if several electrical devices are operated on the same circuit.



IPS InLine® – Conventional metal-ceramic

Firing parameters

IPS InLine Conventional metal-ceramic	Firing temperature T [°C/°F]	Stand-by temperature B [°C/°F]	Closing time S [min]	Heating rate t [°C/°F/min]	Holding time H [min]	Vacuum on V1 [°C/°F]	Vacuum off V2 [°C/°F]
1 st /2 nd Paste Opaquer firing	930/1706	403/757	6:00	100/180	2:00	450/842	929/1704
1 st /2 nd Margin firing	930/1706	403/757	4:00	60/108	1:00	450/842	929/1704
1 st Dentin/Incisal firing / Gingiva	910/1670	403/757	4:00	60/108	1:00	450/842	909/1668
2 nd Dentin/Incisal firing / Gingiva	900/1652	403/757	4:00	60/108	1:00	450/842	899/1650
Margin Add-On firing	900/1652	403/757	4:00	60/108	1:00	450/842	899/1650
Corrective firing after Dentin/Incisal firing, Add-On	860/1580	403/757	4:00	60/108	1:00	450/842	859/1578
Stain firing with IPS Ivocolor	830/1526	403/757	6:00	60/108	1:00	450/842	829/1524
Glaze firing with IPS Ivoclor	830/1526	403/757	6:00	60/108	1:00	450/842	829/1524
Add-On after Glaze firing (690 °C/1274 °F)	690/1274	403/757	4:00	60/108	1:00	450/842	689/1274



All the firing programs described in these Instructions for Use are run without active cooling. After the holding time, the furnace heater is switched off and furnace head cools down with a device-related cooling gradient with the help of the time-controlled opening of the furnace head. If long-term cooling is conducted, the closed furnace head cools down to 800°C /1472°F or 700°C/1292°F after the heater is switched off, at which point the time-controlled opening of the furnace head provides the device-related cooling gradient.

These firing parameters are guidance values. They are valid for the Programat® furnaces from Ivoclar Vivadent.

Deviations (approx. +/- 10 °C/18 °F) may occur:

- Depending on the furnace generation
- Ceramic furnaces from other manufacturers
- In case of regional differences in the power supply or if several electrical devices are operated on the same circuit.



IPS InLine® One – One-layer metal-ceramic

Investment material mixing ration

Investment material	100 g Investment Ring	200 g Investment Ring	300 g Investment Ring
IPS PressVEST Premium	18 ml liquid 8 ml dist. water	36 ml liquid 16 ml dist. water	54 ml liquid 24 ml dist. water

Pressing

Press parameters for IPS InLine PoM

For pressing the IPS InLine PoM ingot in the EP600, Programat EP 3000/EP 5000 or Programat EP 3010/EP 5010 select the "IPS InLine PoM" program (conduct a software update, if necessary).



After the end of the press cycle (optical and/or acoustic signal) proceed as follows:

- Remove the investment ring from the press furnace using the Investment Ring Tongs immediately after pressing.
- Place the investment ring on a cooling grid to cool in a place protected from draft.
- Do not speed up cooling, e.g. by blasting with compressed air.

Firing parameters

IPS InLine PoM Press-on-Metal ceramic	Firing temperature T [°C/°F]	Stand-by temperature B [°C/°F]	Closing time S [min]	Heating rate t [°C/°F/min]	Holding time H [min]	Vacuum on V ₁ [°C/°F]	Vacuum off V ₂ [°C/°F]
1 st /2 nd Paste Opaquer firing	930/1706	403/757	6:00	100/180	2:00	450/842	929/1704
Touch-Up firing	840/1544	403/757	4:00	60/108	1:00	450/842	839/1542
Stain firing with IPS Ivocolor	710/1310	403/757	6:00	60/108	1:00	450/842	709/1308
Glaze firing with IPS Ivoclor	710/1310	403/757	6:00	60/108	1:00	450/842	709/1308
Add-On after Glaze firing (690 °C/1274 °F)	690/1274	403/757	4:00	60/108	1:00	450/842	689/1272



All the firing programs described in these Instructions for Use are run without active cooling. After the holding time, the furnace heater is switched off and furnace head cools down with a device-related cooling gradient with the help of the time-controlled opening of the furnace head. If long-term cooling is conducted, the closed furnace head cools down to 800°C /1472°F or 700°C/1292°F after the heater is switched off, at which point the time-controlled opening of the furnace head provides the device-related cooling gradient.

These firing parameters are guidance values. They are valid for the Programat® furnaces from Ivoclar Vivadent.

Deviations (approx. +/- 10 °C/18 °F) may occur:

- Depending on the furnace generation
- Ceramic furnaces from other manufacturers
- In case of regional differences in the power supply or if several electrical devices are operated on the same circuit.



IPS InLine® – Veneer

Firing parameters

IPS InLine Veneer	Firing temperature T [°C/°F]	Stand-by temperature B [°C/°F]	Closing time S [min]	Heating rate t [°C/°F/min]	Holding time H [min]	Vacuum on V₁ [°C/°F]	Vacuum off V₂ [°C/°F]
Wash firing	830/1526	403/757	4:00	60/108	1:00	450/842	829/1524
Cervical firing	940/1724	403/757	8:00	60/108	1:00	450/842	939/1722
Dentin / Impulse firing	940/1724	403/757	8:00	60/108	1:00	450/842	939/1722
Incisal firing	930/1706	403/757	8:00	60/108	1:00	450/842	929/1704
Glaze firing with IPS Ivoclor	830/1526	403/757	8:00	60/108	1:00	450/842	829/1524



All the firing programs described in these Instructions for Use are run without active cooling. After the holding time, the furnace heater is switched off and furnace head cools down with a device-related cooling gradient with the help of the time-controlled opening of the furnace head. If long-term cooling is conducted, the closed furnace head cools down to 800°C /1472°F or 700°C/1292°F after the heater is switched off, at which point the time-controlled opening of the furnace head provides the device-related cooling gradient.

These firing parameters are guidance values. They are valid for the Programat® furnaces from Ivoclar Vivadent.

Deviations (approx. +/- 10 °C/18 °F) may occur:









































- Depending on the furnace generation
- Ceramic furnaces from other manufacturers
- In case of regional differences in the power supply or if several electrical devices are operated on the same circuit.



Combination Tables

A–D shades

	reddish-brown					reddish-yellow			
Opaquer									
Intensive Opaquer									
Margin									
Intensiv Margin									
Cervical Dentin									
Deep Dentin									
Dentin									
Transpa Incisal									
Transparent	clear					clear			

shades of grey				reddish-grey		
 C1	 C2	 C3	 C4	 D2	 D3	 D4
 brown			 incisal			
 C1	 C2	 C3	 C4	 D2/D3	 D4	
 add-on		 opaque		 orange		
				 D2/D3	 D2/D3	
 C1	 C2	 C3	 C4	 D2/D3	 D4	
 C1	 C2	 C3	 C4	 D2	 D3	 D4
 T11	 T13	 T13	 T13	 T13	 T13	 T13
clear				clear		

IPS InLine®

Independent of any shade system

Impulse Kit

Occlusal Dentin

orange brown

Mamelon

light salmon yellow-orange

Opal Effect

OE 1 OE 2 OE 3 OE 4 OE 5 OE violet

Transparent

neutral blue brown-grey

Cervical Incisal

orange yellow

Gingiva Kit

Gingiva Opaquer

pink **Gingiva** G1 G2 G3 G4 G5

Intensive Gingiva

IG1 IG2 IG3 IG4

IPS Ivocolor

Shade

Shade 0 Shade 1 Shade 2 Shade 3 Shade 4 Shade 5 Shade 6 Shade 7

Shade Incisal

Shade Incisal 1 Shade Incisal 2 Shade Incisal 3







Stains

E01 white E02 cream E03 lemon E04 sunset E05 copper E06 hazel E07 olive E08 khaki















E09 terracotta E10 mahogany E11 cappuccino E12 espresso E13 terra E14 profundo E15 ocean E16 sapphire

E17 anthracite E18 black E19 rose E20 coral E21 basic red E22 basic yellow E23 basic blue







Bleach Kit BL

Opaquer		
Margin		<p>The Margin materials are only available in shades BL1 and BL4. The shades BL2 and BL3 are achieved with the following mixing ratios:</p> <ul style="list-style-type: none"> - BL2 = 2/3 BL1 : 1/3 BL4 - BL3 = 1/3 BL1 : 2/3 BL4
Deep Dentin		<p>The Deep Dentin materials are only available in shades BL1 and BL4. The shades BL2 and BL3 are achieved with the following mixing ratios:</p> <ul style="list-style-type: none"> - BL2 = 2/3 BL1 : 1/3 BL4 - BL3 = 1/3 BL1 : 2/3 BL4
Dentin		
Incisal		
Add-On		

IPS InLine® PoM

Opaquer A–D	BL1, BL2, BL3, BL4	A1, B1	A2, B2, C1, D2	A3, A3.5	B3, B4	C2, D3, D4	A4, C3, C4
Ingots							
Touch Up							

IPS InLine® One

Opaquer AD	BL1, BL2, BL3, BL4	A1, B1	A2, B2, C1, D2	A3, A3.5	B3, B4	C2, D3, D4	A4, C3, C4
Dentcisal							

Ivoclar Vivadent – worldwide

Ivoclar Vivadent AG
Bendererstrasse 2
9494 Schaan
Liechtenstein
Tel. +423 235 35 35
Fax +423 235 33 60
www.ivoclarvivadent.com

Ivoclar Vivadent Pty. Ltd.
1 – 5 Overseas Drive
P.O. Box 367
Noble Park, Vic. 3174
Australia
Tel. +61 3 9795 9599
Fax +61 3 9795 9645
www.ivoclarvivadent.com.au

Ivoclar Vivadent GmbH
Tech Gate Vienna
Donau-City-Strasse 1
1220 Wien
Austria
Tel. +43 1 263 191 10
Fax: +43 1 263 191 111
www.ivoclarvivadent.at

Ivoclar Vivadent Ltda.
Alameda Caiapós, 723
Centro Empresarial Tamboré
CEP 06460-110 Barueri – SP
Brazil
Tel. +55 11 2424 7400
www.ivoclarvivadent.com.br

Ivoclar Vivadent Inc.
1-6600 Dixie Road
Mississauga, Ontario
L5T 2Y2
Canada
Tel. +1 905 670 8499
Fax +1 905 670 3102
www.ivoclarvivadent.us

Ivoclar Vivadent Shanghai Trading Co., Ltd.
2/F Building 1, 881 Wuding Road,
Jing An District
200040 Shanghai
China
Tel. +86 21 6032 1657
Fax +86 21 6176 0968
www.ivoclarvivadent.com

Ivoclar Vivadent Marketing Ltd.
Calle 134 No. 7-B-83, Of. 520
Bogotá
Colombia
Tel. +57 1 627 3399
Fax +57 1 633 1663
www.ivoclarvivadent.co

Ivoclar Vivadent SAS
B.P. 118
74410 Saint-Jorioz
France
Tel. +33 4 50 88 64 00
Fax +33 4 50 68 91 52
www.ivoclarvivadent.fr

Ivoclar Vivadent GmbH
Dr. Adolf-Schneider-Str. 2
73479 Ellwangen, Jagst
Germany
Tel. +49 7961 889 0
Fax +49 7961 6326
www.ivoclarvivadent.de

Ivoclar Vivadent Marketing (India) Pvt. Ltd.
503/504 Raheja Plaza
15 B Shah Industrial Estate
Veera Desai Road, Andheri (West)
Mumbai, 400 053
India
Tel. +91 22 2673 0302
Fax +91 22 2673 0301
www.ivoclarvivadent.in

Ivoclar Vivadent Marketing Ltd.
The Icon
Horizon Broadway BSD
Block M5 No. 1
Kecamatan Cisauk Kelurahan Sampora
15345 Tangerang Selatan – Banten
Indonesia
Tel. +62 21 3003 2932
Fax +62 21 3003 2934
www.ivoclarvivadent.com

Ivoclar Vivadent s.r.l.
Via Isonzo 67/69
40033 Casalecchio di Reno (BO)
Italy
Tel. +39 051 6113555
Fax +39 051 6113565
www.ivoclarvivadent.it

Ivoclar Vivadent K.K.
1-28-24-4F Hongo
Bunkyo-ku
Tokyo 113-0033
Japan
Tel. +81 3 6903 3535
Fax +81 3 5844 3657
www.ivoclarvivadent.jp

Ivoclar Vivadent Ltd.
4F TAMIYA Bldg.
215 Baumoe-ro
Seocho-gu
Seoul, 06740
Republic of Korea
Tel. +82 2 536 0714
Fax +82 2 6499 0744
www.ivoclarvivadent.co.kr

Ivoclar Vivadent S.A. de C.V.
Calzada de Tlalpan 564,
Col Moderna, Del Benito Juárez
03810 México, D.F.
México
Tel. +52 (55) 50 62 10 00
Fax +52 (55) 50 62 10 29
www.ivoclarvivadent.com.mx

Ivoclar Vivadent BV
De Fruittuinen 32
2132 NZ Hoofddorp
Netherlands
Tel. +31 23 529 3791
Fax +31 23 555 4504
www.ivoclarvivadent.com

Ivoclar Vivadent Ltd.
12 Omega St, Rosedale
PO Box 303011 North Harbour
Auckland 0751
New Zealand
Tel. +64 9 914 9999
Fax +64 9 914 9990
www.ivoclarvivadent.co.nz

Ivoclar Vivadent Polska Sp. z o.o.
Al. Jana Pawła II 78
00-175 Warszawa
Poland
Tel. +48 22 635 5496
Fax +48 22 635 5469
www.ivoclarvivadent.pl

Ivoclar Vivadent LLC
Prospekt Andropova 18 korp. 6/
office 10-06
115432 Moscow
Russia
Tel. +7 499 418 0300
Fax +7 499 418 0310
www.ivoclarvivadent.ru

Ivoclar Vivadent Marketing Ltd.
Qlaya Main St.
Siricon Building No.14, 2nd Floor
Office No. 204
P.O. Box 300146
Riyadh 11372
Saudi Arabia
Tel. +966 11 293 8345
Fax +966 11 293 8344
www.ivoclarvivadent.com

Ivoclar Vivadent S.L.U.
Carretera de Fuencarral nº24
Portal 1 – Planta Baja
28108-Alcobendas (Madrid)
Spain
Tel. +34 91 375 78 20
Fax +34 91 375 78 38
www.ivoclarvivadent.es

Ivoclar Vivadent AB
Dalvägen 14
169 56 Solna
Sweden
Tel. +46 8 514 939 30
Fax +46 8 514 939 40
www.ivoclarvivadent.se

Ivoclar Vivadent Liaison Office
: Tesvikiye Mahallesi
Sakayik Sokak
Nisantas' Plaza No:38/2
Kat:5 Daire:24
34021 Sisli – Istanbul
Turkey
Tel. +90 212 343 0802
Fax +90 212 343 0842
www.ivoclarvivadent.com

Ivoclar Vivadent Limited
Compass Building
Feldspar Close
Warrens Business Park
Enderby
Leicester LE19 4SD
United Kingdom
Tel. +44 116 284 7880
Fax +44 116 284 7881
www.ivoclarvivadent.co.uk

Ivoclar Vivadent, Inc.
175 Pineview Drive
Amherst, N.Y. 14228
USA
Tel. +1 800 533 6825
Fax +1 716 691 2285
www.ivoclarvivadent.us

Rx ONLY
For dental use only!



Manufacturer:
Ivoclar Vivadent AG, 9494 Schaan, Liechtenstein
www.ivoclarvivadent.com

Date information prepared: 2017-07-31, Rev. 0

These materials have been developed solely for use in dentistry. Liability cannot be accepted for damages resulting from failure to observe the instructions or the stipulated area of application. The user is responsible for testing the products for their suitability and use for any purpose not explicitly stated in the instructions. These regulations also apply if the materials are used in conjunction with products of other manufacturers. Descriptions and data constitute no warranty of attributes and are not binding.

Printed in Germany
© Ivoclar Vivadent AG, Schaan / Liechtenstein
692742/en

ivoclar
vivadent[®]
technical